

「將心比心」將四字理念堅持20餘年，讓嘉澎成為全台最大的工業管材銷售品牌。

從1997年以來，我們以專業、體貼、品質穩定的特色，拿下 Hershey Valve (鑽琪牌) 產品代理權，堅持使用完全無添加塑化劑的塑膠材料，通過美國NSF、UL、英國LPCB、WRAS等多項品質認證，並藉由完善的物流配送能力，提供超過9000家廠商的服務經驗，成為業界具領導地位的品牌。

2016年我們以獨特的「五大面向」企業績效制度，通過 B Lab 評比成為全台第一家通過「B型企業*」認證之優質傳產。

2018年我們以20年來銷售經驗奠基，包括塑膠硬管、軟管、工業閥、自動閥、流量計等多樣產品，並設立行銷部門、成立次世代官網，提供更貼近消費者的使用體驗，轉型成為工業管材的多方位銷售商。

未來，我們會持續堅持理念、堅持做對的事；期許某天，將正向態度散播到整個產業，讓我們一起「為世界創造效益，讓獲利擁有意義」

*由嘉澎塑膠有限公司通過認證

專業性
即時新知上線

機動性
完善配送服務





全面性
產品全面供給

服務性
20年豐富經驗

我們比一般企業在乎更多...

個人價值



企業經營

社會回饋

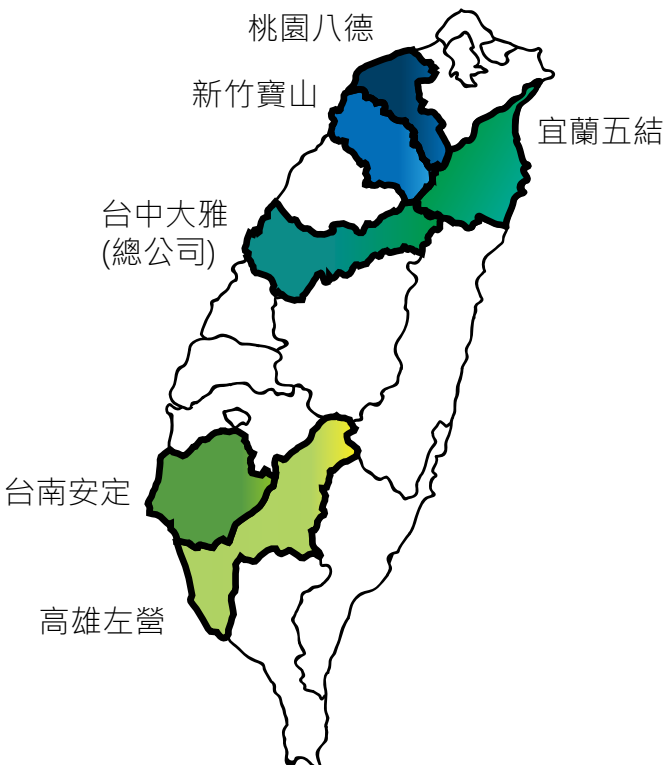

環境永續

顧客服務

營運據點



目 錄

	VP-220 Y/T 型過濾器 Y/T Type Strainer	P.06
	VP-450 工業用擺動式逆止閥 Swing Check Valve	P.10
	VP-460 單由令球型逆止閥 Ball Check Valve	P.12
	VP-470 單由令球型逆止閥(終端) Ball Check (Foot) Valve	P.14
	VP-470F 單由令球型逆止閥(終端) Ball Check (Foot) Valve	P.16
	VP-640 雙邊由令球閥 Double Union Ball Valve	P.18
	VP-640F 雙邊由令球閥(法蘭) Double Flange Ball Valve	P.20
	VP-710 法蘭式隔膜閥 Diaphragm Valve (Flanged)	P.22
	VP-730 由令式隔膜閥 Diaphragm Valve	P.24
	VP-810 把手式蝶閥 Butterfly Valve (Handle type)	P.26
	VP-820 齒輪式蝶閥 Butterfly Valve (Gear Box)	P.28
	VP-900/910 球閥(經濟型) Compact Ball Valve	P.30

VP-240 由令	Unions	P.32
VP-250 盲法蘭	Blind Flanges	P.34
VP-260 單片式法蘭	One-piece(TS) Flanges	P.36
VP-270 兩片式法蘭	Two-pieces(Van Stone) Flanges	P.38
VP-289 橡膠墊片	Rubber Gaskets	P.40

厚管	Pipe	P.42
90°彎頭	90°Elbow	P.43
45°彎頭	45°Elbow	P.44
直接頭	Coupling	P.45
三通	Tee	P.46
十字通/異徑十字通	Cross/Reducer Cross	P.47
管帽	Cap	P.48
Y三通/異徑Y三通	Y-Tee/Reducer Y-Tee	P.49
外牙接頭(閥接頭)	Male Adapter	P.50
異徑直接頭	Reducer Coupling	P.51
異徑三通	Reducer Tee	P.52
異徑接頭(卜申)	Reducer Bushing	P.53

透明流體管	Clear PVC Pipe	P.56
透明配件 (90°彎頭、45°彎頭、直接頭、三通)	Clear PVC Fitting	P.57
膠水	Glue	P.61
預黏膠	Wash Clean	P.61
焊條	Flux	P.61
實績表	Performance Table	P.62

使用說明

- 1.規格表外之尺寸規格，歡迎來電洽談訂製
- 2.本型錄之牌價均以新台幣計價，異動不另行通知
- 3.本型錄之產品規範如有修正，將不另行通知

產品規格說明與性能

Product specifications and performance

產品規範

	UPVC	CPVC
材質	ASTM D1784 或CNS14442之12454(PVC 1120)	ASTM D1784 或CNS14442之23447(CPVC 4120)
直管	ASTM D1785 (SCH40、SCH80)	ASTM F441 (SCH40、SCH80)
配件	ASTM D2464 (SCH80牙接) ASTM D2467 (SCH80套接) ASTM D2466 (SCH40套接)	ASTM F437 (SCH80牙接) ASTM F439 (SCH80套接) ASTM F438 (SCH40套接)
溶劑	ASTM F402	ASTM F402
標示	直管和配件應清楚標示廠商名稱或商標 生產日期、材料等級、適用ASTM標準以及認證標幟	

產品特性

物理特性	單位	UPVC	CPVC	PP	PVDF
操作溫度(持續) Service temperature(Continuous)	°C	5~50	0~90	0~80	-20~120
操作溫度(瞬間) Service temperature(Short hours)	°C	60	100	90	130
熱膨脹係數 Linear thermal coefficient of expansion	/°C	7X10 ⁻⁵	7X10 ⁻⁵	12X10 ⁻⁵	12X10 ⁻⁵
熱傳導係數 Thermal conductivity	kcal/mh°C	0.13	0.12	0.10	0.11
比重 Specific gravity	—	1.40	1.55	0.92	1.77
張力強度 Tensile strength	kgf/cm ²	480 and over	500 and over	250 and over	500 and over
彎曲強度 Bending strength	kgf/cm ²	800 and over	900 and over	250 and over	660 and over

溫度與壓力對照表

工作溫度		*壓力遞減常數		工作溫度		*壓力遞減常數	
°F	°C	UPVC	CPVC	°F	°C	UPVC	CPVC
73	23	1.00	1.00	140	60	0.22	0.50
80	27	0.90	1.00	150	66	-	0.45
90	32	0.75	0.91	160	71	-	0.40
100	38	0.62	0.82	170	77	-	0.32
110	43	0.50	0.73	180	82	-	0.25
120	49	0.45	0.65	190	88	-	0.22
130	54	0.30	0.57	200	93	-	0.20

*法蘭接合處不應超過該尺寸常數之70%；牙口接合處不應超過該尺寸常數之50%

化性表

介質	濃度 (%)	°C	PVC	CPVC	PP	PVDF	PTFE	EPDM	FPM
氯化鈉 Sodium chloride	Saturated Water Solution	40	◎	◎	◎	◎	◎	◎	◎
		60	○	◎	◎	◎	◎	◎	◎
		80		◎	○	◎	◎	○	◎
鹽酸 Hydrochloric acid	35	40	◎	◎	◎	◎	◎	X	X
		60	○	◎	○	◎	◎		
		80		○		◎	◎		
氫氧化鈉 Caustic soda	50	40	◎	△	◎	○	◎	◎	X
		60	○		◎		◎	○	
		80			○		◎		
鉻酸 Chromic acid	20	40	△			◎	◎	○	
		60				◎	◎	○	
		80				○	◎		
醋酸 Acetic acid	50	40	△	△	◎	◎	◎	X	X
		60			○	◎	◎		
		80				○	◎		
硝酸 Nitric acid	50	40	△	○	X	◎	◎	X	○
		60				○	◎		
		80					◎		
甲苯 Toluene		40	X	X	X	△	◎	X	X
		60					◎		
		80					◎		
硫化氫 Hydrogen sulfide	Aqueous	40	◎	◎	◎	◎	◎	◎	◎
		60	○	◎	◎	◎	◎	◎	○
		80		○	○	◎	◎	○	
硫酸 Sulfuric acid	90	40	X	◎	X	◎	◎	X	○
		60		○		◎	◎		
		80				○	◎		

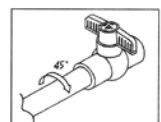
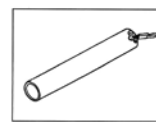
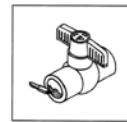

安裝說明

1. 於閥門內壁及管道外壁塗抹膠水，過少過多皆會影響接合強度或流體順暢性，請適量塗抹
2. 當表面仍濕潤時，立即連接閥門與管道，並確保管道推至底部，在推進同時將管道轉動1/4圈，當管道達底部時須持續加壓約15~20秒
3. 本產品為工業級製品，建議使用專用膠接合，確保承受流體之強度，
4. 《膠水接口固化時間》參閱59頁

- ◎ 很少或無影響
- 輕微影響
- △ 嚴重影響
- × 不適用

VP-220 Y型過濾器

Y Type Strainer



UPVC-插管式



CPVC-插管式



UPVC-由令式



CPVC-由令式



透明-由令式

- 濾網拆卸清洗方便
- 過濾用·可承受酸鹼雜質流體
- 濾網規格:
PE / 20 mesh
SUS / 40/ 60 mesh
- 註:
Comparative Particle size
20 Mesh≒0.034 inches
40 Mesh≒0.015 inches
60 Mesh≒0.0092 inches

品號	尺寸	規格	材質	墊圈/O環	接口
VP-220 Y	1/2"~4"	ANSI, JIS, DIN	UPVC	EPDM, FPM	Union, Socket, Flanged
VP-221 Y	1/2"~4"	ANSI, JIS, DIN	CPVC	EPDM, FPM	Union, Socket, Flanged

編號	零件名稱		材質	數量
1	BODY	本體	UPVC, CPVC	1
2	CAP	管帽 2-1/2"~4"	UPVC, CPVC	1
3	UNION NUT	螺帽	UPVC, CPVC	1
4	FILTER	濾網	PP, PE, SUS	1
5	SET RING	卡環	UPVC, CPVC	1
6	O-RING	O環	EPDM, FPM	1
7	FILTER HOLDER	濾網架 1/2"~2"	UPVC, CPVC	1
8	RETAINING RING	塞子 1/2"~2"	UPVC, CPVC	1
9	FLANGE	法蘭片	UPVC, CPVC	2
10	UNION	由令	UPVC, CPVC	2
11	PIPE	直管	UPVC, CPVC	2
12	INNER BODY	內濾網本體 2-1/2"~4"	UPVC, CPVC	1
13	OUTER BODY	外濾網本體 2-1/2"~4"	UPVC, CPVC	1
14	END CONNECTOR	外特普 2-1/2"	UPVC, CPVC	2

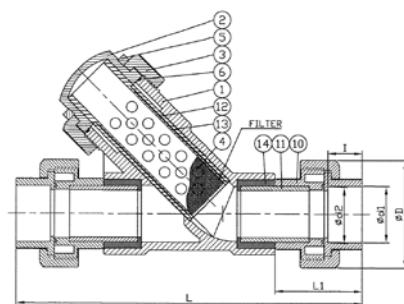

2-1/2" ~ 4"

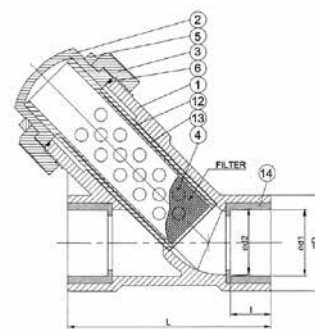

2-1/2" ~ 4"

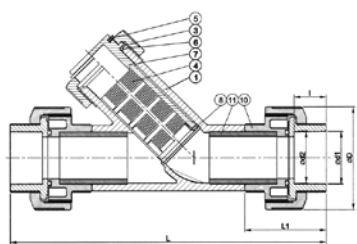

1/2" ~ 2"

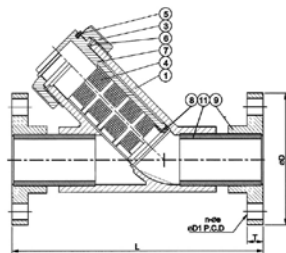

1/2" ~ 2"

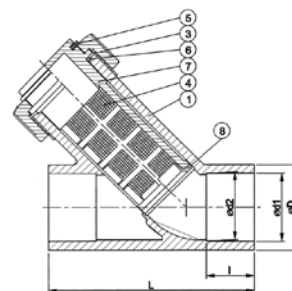

1/2" ~ 2"

牌 價 (單位 / 元)

品號		VP-220 Y			VP-221 Y		
材質		UPVC			CPVC		
*墊圈/O環		EPDM			FPM		
接口		由令	插管	法蘭	由令	插管	法蘭
1/2"	15A	1216	1104	1320	1400	1200	1500
3/4"	20A	1452	1320	1584	1680	1440	1800
1"	25A	1584	1440	1848	1960	1680	2100
1-1/4"	32A	2024	1840	2288	2426	2080	2600
1-1/2"	40A	2712	2464	2992	3173	2720	3400
2"	50A	3960	3600	4224	4480	3840	4800
2-1/2"	65A	9618	9135	9872	10916	9747	11206
3"	80A	9160	8700	9400	10398	9282	10670
4"	100A	16014	15212	15150	18178	16231	17198

*2"以下標準濾網為PE/20目 · 2-1/2"以上標準濾網為PP/10目

Union

Nom.		SIZE	15mm (1/2")	20mm (3/4")	25mm (1")	32mm (1-1/4")	40mm (1-1/2")	50mm (2")	65mm (2-1/2")	80mm (3")	100mm (4")
JIS	d1		22.3	26.3	32.33	38.43	48.46	60.56	76.6	89.6	114.7
	d2		21.7	25.7	31.67	37.57	47.54	59.44	75.87	88.83	113.77
			22.22	25.4	28.58	31.75	34.93	38.1	44.45	47.63	69
ANSI	d1	UPVC	21.54	26.87	33.65	42.42	48.56	60.63	73.38	89.31	114.76
		CPVC								89.28	114.73
	d2	UPVC	21.23	26.57	33.27	42.04	48.11	60.17	72.85	88.7	114.1
		CPVC								88.67	114.04
			22.22	25.4	28.58	31.75	34.93	38.1	44.45	47.63	57.15
DIN	d1		20.3	25.3	32.3	40.3	50.3	63.3	75.35	90.5	110.6
	d2		19.9	24.9	31.9	39.9	49.9	62.9	74.9	89.9	109.9
			16	19	22	26	31	38	44	51	61
	D		46.5	55	66	82	98	120	140	163	225
	L		202	233	261	324	334	377	450	476	601
	L1		56	64	72	87	90	98	114	127	162

Socket

Nom.		SIZE	15mm (1/2")	20mm (3/4")	25mm (1")	32mm (1-1/4")	40mm (1-1/2")	50mm (2")	65mm (2-1/2")	80mm (3")	100mm (4")
ANSI	d1	UPVC	21.54	26.87	33.65	42.42	48.56	60.63	73.38	89.31	114.76
		CPVC								89.28	114.73
	d2	UPVC	21.23	26.57	33.27	42.04	48.11	60.17	72.85	88.7	114.1
		CPVC								88.67	114.04
			22.22	25.4	28.58	31.75	34.93	38.1	44.15	49	59.5
	D		30	36	44	61	61	77	106	106	132
	L		90	105	117	154.5	154.5	181	222	222	277

Flanged

Nom.		SIZE	15mm (1/2")	20mm (3/4")	25mm (1")	32mm (1-1/4")	40mm (1-1/2")	50mm (2")	65mm (2-1/2")	80mm (3")	100mm (4")
JIS	D		95	100	125	135	140	155	178	185	210
	D1		70	75	90	100	105	120	140	150	175
	L		160	175	202	245	247	295	375	413	472
	T		14	15	15	16	16	20	22	22	22
	n-øe		4-Ø15	4-Ø15	4-Ø19	4-Ø19	4-Ø19	4-Ø19	4-Ø19	4-Ø19	8-Ø19
ANSI	D		89	98	108	117	127	152	178	191	229
	D1		61	70	79	89	98	121	140	152	191
	L		154	170	200	245	250	290	375	400	465
	T		11	12	14	16	17.5	19	22	23.5	24
	n-øe		4-Ø16	4-Ø16	4-Ø16	4-Ø16	4-Ø16	4-Ø19	4-Ø19	4-Ø19	8-Ø19

VP-220 T型過濾器

T Type Strainer



HI-PVC



CPVC



PP

- 濾網拆卸清洗方便
- 過濾用，可承受酸鹼雜質流體
- 濾網規格：
SUS 304/ 316, 60/ 40/ 20 mesh
PP/PVC/CPVC
3 ~ 8mm孔目等客戶訂製規格
- 註：
Comparative Particle size
20 Mesh≒0.034 inches
40 Mesh≒0.015 inches
60 Mesh≒0.0092 inches

品號	尺寸	規格	材質	墊圈/O環	接口
VP-220 T	1/2"~8"	ANSI, JIS, DIN	HI-PVC	EPDM, PTFE, FPM	Flanged
VP-221 T	1/2"~8"	ANSI, JIS, DIN	CPVC	EPDM, PTFE, FPM	Flanged
VP-224 T	1/2"~8"	ANSI, JIS, DIN	PP	EPDM, PTFE, FPM	Flanged

編號	零件名稱		材質	數量
1	BODY	本體	HI-PVC, CPVC	1
2	BONNET	上蓋	HI-PVC, CPVC	1
3	90°ELL	90度彎頭	UPVC, CPVC	1
4	INNER BODY	內濾網本體	UPVC, CPVC	1
5	OUTER BODY	外濾網本體	UPVC, CPVC	1
6	GASKET	本體墊圈	EPDM, FPM	1
7	FILTER	濾網	PP, SUS	1
8	BOLT SETS	螺絲組	STEEL, SUS304	8~16

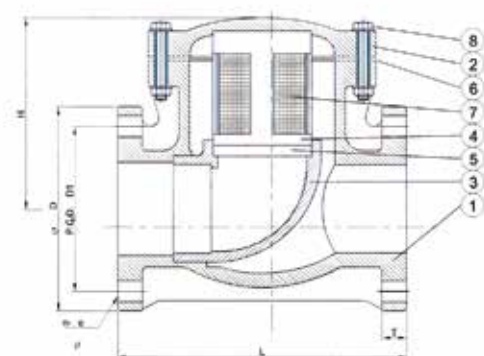

牌 價 (單位 / 元)

品號		VP-220 T		VP-221 T		VP-224 T		
材質		UPVC		CPVC		PP		
*墊圈/O環		EPDM	FPM	EPDM	FPM	EPDM	FPM	PTFE
接口		法蘭						
1/2"	15A	3488	4056	5278	5444	4011	4664	4898
3/4"	20A	3488	4056	5278	5444	4011	4664	4898
1"	25A	4025	4396	6082	6453	4629	5055	5309
1-1/4"	32A	5010	5540	7514	8267	5762	6371	6689
1-1/2"	40A	5010	5540	7514	8267	5762	6371	6689
2"	50A	6083	6629	9124	9671	6995	7623	8004
2-1/2"	65A	8496	9169	12790	13464	9770	10544	11071
3"	80A	10106	10940	15205	16038	11622	12581	13211
4"	100A	14490	15562	21735	22807	16664	17896	18791
6"	150A	25530	27587	41235	43291	29360	31725	33311
8"	200A	47570	50796	76700	123216	54706	58415	61336

*標準濾網為SUS316/40目

Nom. \ SIZE		50mm (2")	65mm (2-1/2")	80mm (3")	100mm (4")	150mm (6")	200mm (8")
JIS	D	155	175	185	210	285	330
	D1	120	140	150	175	240	290
	n-øe	4-Ø19	4-Ø19	8-Ø19	8-Ø19	8-Ø23	12-Ø23
ANSI	D	152	178	191	229	285	343
	D1	121	140	152	191	241	299
	n-øe	4-Ø19	4-Ø19	4-Ø19	8-Ø19	8-Ø23	8-Ø23
DIN	D	165	185	200	220	285	343
	D1	125	145	160	180	240	295
	n-øe	4-Ø18	4-Ø18	8-Ø18	8-Ø18	8-Ø22	8-Ø22
L		200	240	260	300	400	500
H		165	168.5	169	217	285	338
T		20	22	22	24	26	30

VP-450 工業用擺動式逆止閥

Swing Check Valve



HI-PVC



CPVC



PP

- 最低開啓壓力：2 PSI
- 依流向箭頭指示水平或垂直安裝
- 可直接清理閥體，無須自管路拆除
- 前端管路建議安裝過濾器，以防閥門被阻塞

品號	尺寸	規格	材質	墊圈	接口
VP-450	1/2"~8"	ANSI, JIS, DIN	HI-PVC	EPDM, FPM, PTFE	Flanged
VP-451	1/2"~8"	ANSI, JIS, DIN	CPVC	EPDM, FPM, PTFE	Flanged
VP-453	1/2"~8"	ANSI, JIS, DIN	PVDF	EPDM, FPM, PTFE	Flanged
VP-454	1/2"~8"	ANSI, JIS, DIN	PP	EPDM, FPM, PTFE	Flanged

編號	零件名稱		材質	數量
1	BODY	本體	HI-PVC, CPVC, PP, PVDF	1
2	BONNET	上蓋	HI-PVC, CPVC, PP, PVDF	1
3	DISC	擺動盤	HI-PVC, CPVC, PP, PVDF	1
4	DISC HOLDER	墊盤2"~8"	HI-PVC, CPVC, PP, PVDF	1
5	ARM	擺臂	HI-PVC, CPVC, PP, PVDF	1
6	DISC GASKET	止洩圈	EPDM, FPM, NBR, PTFE	1
7	GASKET	本體墊圈	EPDM, FPM, NBR, PTFE	1
8	SHAFT	轉軸	PTFE	1
9	DISC NUT	螺帽	HI-PVC, CPVC, PP, PVDF	1-2
10	DISC WASHER	華司	HI-PVC, CPVC, PP, PVDF	1
11	SHEET GASKET	襯墊	EPDM, FPM, NBR, PTFE	1
12	SHEET BOLT	本體螺栓	HI-PVC, CPVC, PP, PVDF	1
13	DISC BOLT	墊盤螺栓	HI-PVC, CPVC, PP, PVDF	1-8
14	BOLT SETS	螺絲組	STEEL, SUS 304	6-16

牌 價 (單位 / 元)

品號		VP-450		VP-451		VP-453	VP-454	
材質		UPVC		CPVC		PVDF	PP	
墊圈		EPDM	FPM	EPDM	FPM	FPM	EPDM	FPM
接口		法蘭						
1/2"	15A	3033	4045	4589	6067	7934	3578	4589
3/4"	20A	3033	4045	4589	6067	7934	3578	4589
1"	25A	3500	4589	5288	6923	12600	4123	5211
1-1/2"	40A	4356	5522	6534	8322	18122	5133	6300
2"	50A	5289	7078	7934	10656	24578	6378	8167
2-1/2"	65A	7388	9490	11122	14234	32667	8945	11045
3"	80A	8788	11356	13222	17034	37334	10578	13145
4"	100A	12600	15633	18900	23489	57556	15167	18200
6"	150A	22200	26810	35856	43322	117678	28622	33600
8"	200A	45750	55360	74115	89683	177750	57360	67283

Nom.	SIZE	15mm	20mm	25mm	32mm	40mm	50mm	65mm	80mm	100mm	150mm	200mm
		(1/2")	(3/4")	(1")	(1-1/4")	(1-1/2")	(2")	(2-1/2")	(3")	(4")	(6")	(8")
JIS	D	100	100	125	140	140	155	175	185	210	285	343
	D1	70	75	90	100	105	120	140	150	175	240	290
	L	140	140	160	180	180	200	240	260	300	400	500
	n-øe	4-Ø15	4-Ø15	4-Ø19	4-Ø19	4-Ø19	4-Ø19	4-Ø19	8-Ø19	8-Ø19	8-Ø23	12-Ø23
ANSI	D	100	100	108	127	127	152	178	191	229	285	343
	D1	61	70	79	89	98	121	140	152	191	241	299
	L	140	140	160	180	180	200	240	260	300	400	500
	n-øe	4-Ø16	4-Ø16	4-Ø16	4-Ø16	4-Ø16	4-Ø19	4-Ø19	4-Ø19	8-Ø19	8-Ø23	8-Ø23
DIN	D	100	100	115	150	150	165	185	200	220	285	343
	D1	65	75	85	100	110	125	145	160	180	240	295
	L	140	140	160	180	180	200	240	260	300	400	500
	n-øe	4-Ø14	4-Ø14	4-Ø14	4-Ø18	4-Ø18	4-Ø18	4-Ø18	8-Ø18	8-Ø18	8-Ø22	8-Ø22
T	15	15	17	19	19	20	22	22	24	26	30	
H	93	93	117.5	137	137	165	168.5	169	217	285	338	

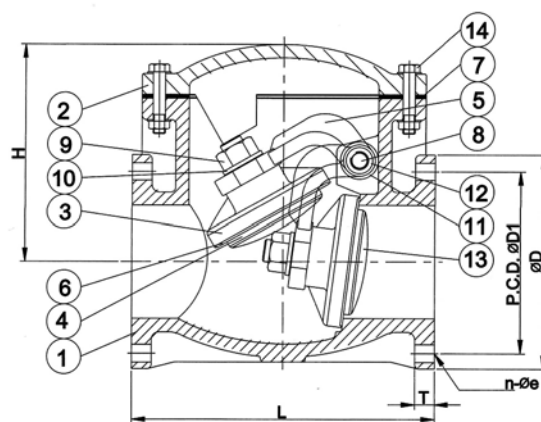
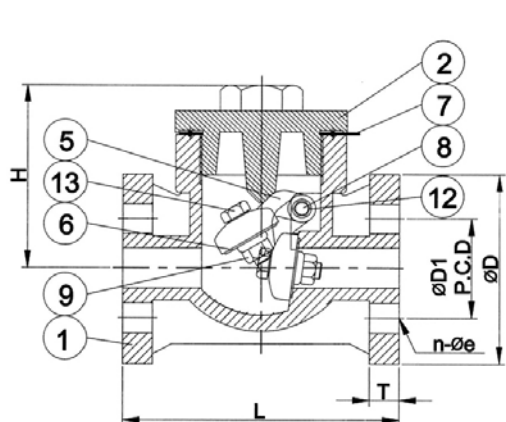

VP-460 單由令球型逆止閥

Ball Check Valve



UPVC



CPVC



PP

- 工作壓力：1/2"~2-1/2" 150 PSI, 3"~4" 100 PSI@73.4°F(23°C)
- 最低開啓壓力：2 ~ 4 PSI
- 依流向箭頭指示垂直安裝，可防止流體逆流
- 球體逆止設計，密閉性佳

品號	尺寸	規格	材質	止逆座	接口
VP-460	1/2"~4"	ANSI, JIS, DIN	UPVC	EPDM, FPM	Socket, Threaded, Flanged
VP-461	1/2"~4"	ANSI, JIS, DIN	CPVC	EPDM, FPM	Socket, Threaded, Flanged
VP-463	1/2"~4"	ANSI, JIS, DIN	PVDF	EPDM, FPM	Socket, Threaded, Flanged
VP-464	1/2"~4"	ANSI, JIS, DIN	PP	EPDM, FPM	Socket, Threaded, Flanged

VP-460

編號	零件名稱		材質	數量
1	BODY	本體	UPVC, CPVC, PP, PVDF	1
2	UNION NUT	螺帽	UPVC, CPVC, PP, PVDF	1
3	END CONNECTOR	外特普	UPVC, CPVC, PP, PVDF	1
4	BALL	球體	UPVC, CPVC, PP, PVDF	1
5	GLAND	卡環	UPVC, CPVC, PP, PVDF	1
6	SEAL	止逆座	EPDM, FPM, NBR	1
7	FLANGE	法蘭片	UPVC, CPVC, PP, PVDF	2
8	FILTER	濾網	UPVC, CPVC, PP, PVDF	1

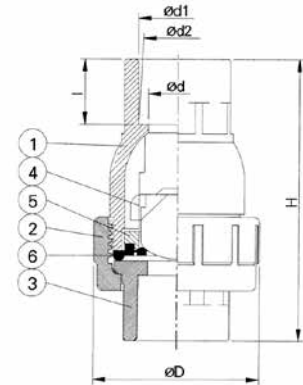

VP-460 Socket / Threaded

Nom.	SIZE	15mm	20mm	25mm	32mm	40mm	50mm	65mm	80mm	100mm	
		(1/2")	(3/4")	(1")	(1-1/4")	(1-1/2")	(2")	(2-1/2")	(3")	(4")	
JIS	d1	22.3	26.3	32.33	38.43	48.46	60.56	76.6	89.6	114.7	
	d2	21.7	25.7	31.67	37.57	47.54	59.44	75.87	88.83	113.77	
	l	22.22	25.4	28.58	31.75	34.93	38.1	61	63	69	
ANSI	d1	UPVC	21.54	26.87	33.65	42.42	48.56	60.63	73.38	89.31	114.76
		CPVC								89.28	114.73
	d2	UPVC	21.23	26.57	33.27	42.04	48.11	60.17	72.85	88.7	114.1
		CPVC								88.67	114.04
	l	22.22	25.4	28.58	31.75	34.93	38.1	44.45	47.63	57.15	
DIN	d1	20.3	25.3	32.3	40.3	50.3	63.3	75.35	90.5	110.6	
	d2	19.9	24.9	31.9	39.9	49.9	62.9	74.9	89.9	109.9	
	l	16	19	22	26	31	38	44	51	61	
thd./in	NPT	14	14	11.5	11.5	11.5	11.5	8	8	8	
	BSPT	14	14	11	11	11	11	11	11	11	
	D	50	62	72	97	97	107	163	163	225	
	d	13	20	25	36	40	50	70	77	102	
	H	93	109	122	155	155	178	262	262	321	

牌 價 (單位 / 元)

品號		VP-460	VP-461		VP-463	VP-464
材質		UPVC	CPVC		PVDF	PP
止逆座		EPDM / FPM	EPDM	FPM	FPM	EPDM / FPM
接口		插管 / 牙口				
1/2"	15A	500	864	1180	2458	580
3/4"	20A	560	1000	1356	2757	673
1"	25A	750	1360	1752	3582	880
1-1/4"	32A	1132	2069	2577	6522	1292
1-1/2"	40A	1200	2440	2948	6760	1520
2"	50A	1560	3175	3967	8000	1880
2-1/2"	65A	2576	6000	7200	15484	3091
3"	80A	3600	6928	8128	18000	4800
4"	100A	7364	12909	14637	34000	9120

品號		VP-460 F	VP-461 F		VP-463 F	VP-464 F
材質		UPVC	CPVC		PVDF	PP
止逆座		EPDM / FPM	EPDM	FPM	FPM	EPDM / FPM
接口		法蘭				
1/2"	15A	650	1168	1484	3200	781
3/4"	20A	780	1368	1724	3875	960
1"	25A	1060	1856	2248	5214	1273
1-1/4"	32A	1520	3168	3676	7040	1600
1-1/2"	40A	1680	3240	3748	7372	1800
2"	50A	2080	4356	5148	8848	2160
2-1/2"	65A	3735	8688	9888	20000	4677
3"	80A	5400	9088	10288	23593	5760
4"	100A	8600	16108	17836	36865	9500

VP-460 F

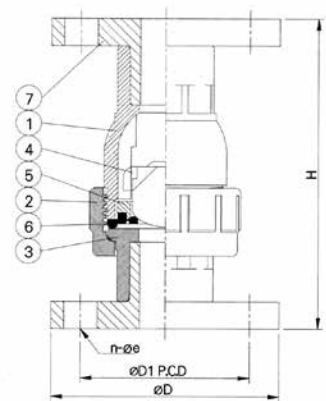

VP-460 F Flanged

Nom.		SIZE	15mm (1/2")	20mm (3/4")	25mm (1")	32mm (1-1/4")	40mm (1-1/2")	50mm (2")	65mm (2-1/2")	80mm (3")	100mm (4")
JIS	D		95.5	100	124.5	134.5	140.5	155	175	184.5	209.5
	D1		70	75	90	100	105	120	140	150	175
	n-øe		4-Ø15	4-Ø15	4-Ø19	4-Ø19	4-Ø19	4-Ø19	4-Ø19	8-Ø19	8-Ø19
	H		122	141	154	191	191	218	306	307	364
ANSI	D		89	98	108	117	127	155	178.5	190.5	230
	D1		61	70	79	89	98	121	140	152	191
	n-øe		4-Ø16	4-Ø16	4-Ø16	4-Ø16	4-Ø16	4-Ø19	4-Ø19	4-Ø19	8-Ø19
	H		115	133	150	187	190	216	306	309	369
DIN	D		95.5	100	124.5	134.5	140.5	155	175	184.5	209.5
	D1		65	75	85	100	110	125	145	160	180
	n-øe		4-Ø15	4-Ø15	4-Ø15	4-Ø19	4-Ø19	4-Ø19	4-Ø19	8-Ø19	8-Ø19
	H		122	141	152	191	191	218	306	307	364

VP-470 單由令球型逆止閥(終端) Ball Check (Foot) Valve



UPVC



CPVC



PP

- 工作壓力：1/2"~2-1/2" 150 PSI,
3"~4" 100 PSI@73.4°F(23°C)
- 最低開啓壓力：2 ~ 4 PSI
- 依流向箭頭指示垂直安裝，可防止流體逆流
- 球體逆止設計，密閉性佳

品號	尺寸	規格	材質	止逆座	接口
VP-470	1/2"~4"	ANSI, JIS, DIN	UPVC	EPDM, FPM	Socket, Threaded
VP-471	1/2"~4"	ANSI, JIS, DIN	CPVC	EPDM, FPM	Socket, Threaded
VP-473	1/2"~4"	ANSI, JIS, DIN	PVDF	EPDM, FPM	Socket, Threaded
VP-474	1/2"~4"	ANSI, JIS, DIN	PP	EPDM, FPM	Socket, Threaded

Nom.	SIZE	15mm	20mm	25mm	32mm	40mm	50mm	65mm	80mm	100mm	
		(1/2")	(3/4")	(1")	(1-1/4")	(1-1/2")	(2")	(2-1/2")	(3")	(4")	
JIS	d1	22.3	26.3	32.33	38.43	48.46	60.56	76.6	89.6	114.7	
	d2	21.7	25.7	31.67	37.57	47.54	59.44	75.87	88.83	113.77	
	l	22.22	25.4	28.58	31.75	34.93	38.1	61	63	69	
ANSI	d1	UPVC	21.54	26.87	33.65	42.42	48.56	60.63	73.38	89.31	114.76
		CPVC								89.28	114.73
	d2	UPVC	21.23	26.57	33.27	42.04	48.11	60.17	72.85	88.7	114.1
		CPVC								88.67	114.04
	l	22.22	25.4	28.58	31.75	34.93	38.1	44.45	47.63	57.15	
DIN	d1	20.3	25.3	32.3	40.3	50.3	63.3	75.35	90.5	110.6	
	d2	19.9	24.9	31.9	39.9	49.9	62.9	74.9	89.9	109.9	
	l	16	19	22	26	31	38	44	51	61	
thd./in	NPT	14	14	11.5	11.5	11.5	11.5	8	8	8	
	BSPT	14	14	11	11	11	11	11	11	11	
	D	60.5	70.7	82.8	110.6	110.6	124	163	163	225	
	d	13	20	25	36	40	50	70	77	102	
	H	137	154	169	204	204	241	321	321	397	

牌 價 (單位 / 元)

品號		VP-470	VP-471		VP-473	VP-474
材質		UPVC	CPVC		PVDF	PP
止逆座		EPDM / FPM	EPDM	FPM	FPM	EPDM / FPM
接口		插管 / 牙口				
1/2"	15A	690	1208	1524	3091	828
3/4"	20A	804	1552	1908	3607	966
1"	25A	1076	2148	2540	4829	1292
1-1/4"	32A	1458	2727	3235	6096	1746
1-1/2"	40A	1560	3208	3716	6773	1816
2"	50A	2000	4324	5116	8700	2332
2-1/2"	65A	3312	6865	8065	12897	4147
3"	80A	4800	8076	9276	20765	5562
4"	100A	9156	13600	15328	42416	11360

編號	零件名稱	材質	數量
1	BODY 本體	UPVC, CPVC, PP, PVDF	1
2	UNION NUT 螺帽	UPVC, CPVC, PP, PVDF	1
3	END CONNECTOR 外特普	UPVC, CPVC, PP, PVDF	1
4	BALL 球體	UPVC, CPVC, PP, PVDF	1
5	GLAND 卡環	UPVC, CPVC, PP, PVDF	1
6	SEAL 止逆座	EPDM, FPM, NBR	1
7	FILTER 濾網	UPVC, CPVC, PP, PVDF	1

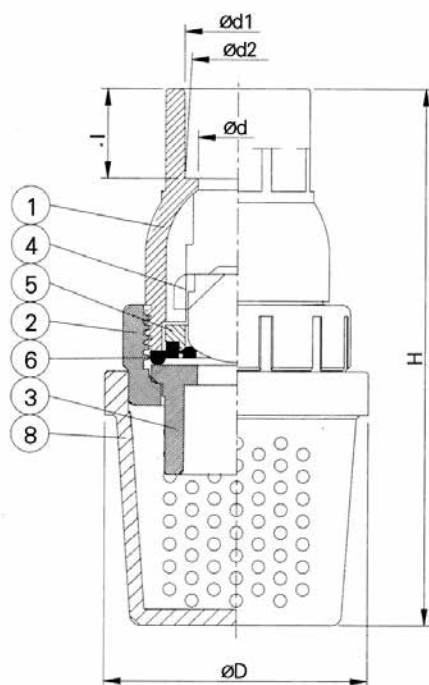

VP-470F 單由令球型逆止閥(終端) Ball Check (Foot) Valve



UPVC



CPVC



PP

- 工作壓力：1/2"~2-1/2" 150 PSI,
3"~4" 100 PSI@73.4°F(23°C)
- 最低開啓壓力：2 ~ 4 PSI
- 依流向箭頭指示垂直安裝，可防止流體逆流
- 球體逆止設計，密閉性佳

品號	尺寸	規格	材質	止逆座	接口
VP-470F	1/2"~8"	ANSI, JIS, DIN	UPVC	EPDM, FPM	Flanged
VP-471F	1/2"~8"	ANSI, JIS, DIN	CPVC	EPDM, FPM	Flanged
VP-473F	1/2"~8"	ANSI, JIS, DIN	PVDF	EPDM, FPM	Flanged
VP-474F	1/2"~8"	ANSI, JIS, DIN	PP	EPDM, FPM	Flanged

Nom.	SIZE	15mm	20mm	25mm	32mm	40mm	50mm	65mm	80mm	100mm
		(1/2")	(3/4")	(1")	(1-1/4")	(1-1/2")	(2")	(2-1/2")	(3")	(4")
JIS	D	95.5	100	124.5	134.5	140.5	155	175	184.5	209.5
	D1	70	75	90	100	105	120	140	150	175
	n-øe	4-Ø15	4-Ø15	4-Ø19	4-Ø19	4-Ø19	4-Ø19	4-Ø19	8-Ø19	8-Ø19
	H	151.5	170	185	222	222	261	343	343.5	418.5
ANSI	D	89	98	108	117	127	155	178.5	190.5	230
	D1	61	70	79	89	98	121	140	152	191
	n-øe	4-Ø16	4-Ø16	4-Ø16	4-Ø16	4-Ø16	4-Ø19	4-Ø19	4-Ø19	8-Ø19
	H	148	166	183	220	221.5	260	343	344.5	421
DIN	D	95.5	100	124.5	134.5	140.5	155	175	184.5	209.5
	D1	65	75	85	100	110	125	145	160	180
	n-øe	4-Ø15	4-Ø15	4-Ø15	4-Ø19	4-Ø19	4-Ø19	4-Ø19	8-Ø19	8-Ø19
	H	151.5	170	185	222	222	261	343	343.5	418.5
D2		60.5	70.7	82.8	110.6	110.6	124	163	163	225

牌 價 (單位 / 元)

品號		VP-470 F	VP-471 F		VP-473 F	VP-474 F
材質		UPVC	CPVC		PVDF	PP
止逆座		EPDM / FPM	EPDM	FPM	FPM	EPDM / FPM
接口		法蘭				
1/2"	15A	896	1512	1828	4018	1076
3/4"	20A	1048	1920	2276	4686	1256
1"	25A	1400	2644	3036	6272	1680
1-1/4"	32A	1792	3936	4444	7364	1972
1-1/2"	40A	2032	4008	4516	8832	2368
2"	50A	2616	5508	6300	11312	3030
2-1/2"	65A	4305	9836	11036	16764	4492
3"	80A	6016	10236	11436	26952	7220
4"	100A	10800	16800	18528	55086	14760
6"	150A	54294				
8"	200A	85416				

編號	零件名稱		材質	數量
1	BODY	本體	UPVC, CPVC, PP, PVDF	1
2	UNION NUT	螺帽	UPVC, CPVC, PP, PVDF	1
3	END CONNECTOR	外特普	UPVC, CPVC, PP, PVDF	1
4	BALL	球體	UPVC, CPVC, PP, PVDF	1
5	GLAND	卡環	UPVC, CPVC, PP, PVDF	1
6	SEAL	止逆座	EPDM, FPM, NBR	1
7	FLANGE	法蘭片	UPVC, CPVC, PP, PVDF	1
8	FILTER	濾網	UPVC, CPVC, PP, PVDF	1

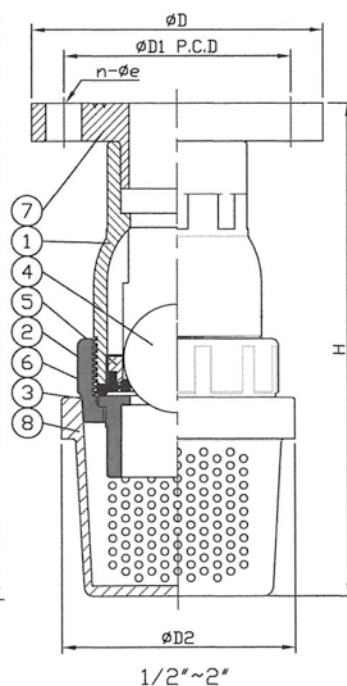

VP-640 雙邊由令球閥

Double Union Ball Valve



UPVC



CPVC



PP

- 工作壓力：150 PSI @73.4°F(23°C)
- 標準流量設計
- 雙由令設計可同時當由令及閥門使用
- 墊座鬆緊可做適度調整
- 不須使用特殊工具即可快速裝配
- 可埋入銅柱加裝自動控制器
- 標準品未埋入銅柱
- 適用於各規格、材質結合
- 另有彩色把手(紅 / 黃 / 藍 / 綠)供選購

品號	尺寸	規格	材質	墊座	O環	接口
VP-640	1/2"~4"	ANSI, JIS, DIN	UPVC	PTFE	EPDM, FPM	Socket, Threaded
VP-641	1/2"~4"	ANSI, JIS, DIN	CPVC	PTFE	EPDM, FPM	Socket, Threaded
VP-643	1/2"~4"	ANSI, JIS, DIN	PVDF	PTFE	FPM	Socket, Threaded
VP-644	1/2"~4"	ANSI, JIS, DIN	PP	PTFE	EPDM, FPM	Socket, Threaded

編號	零件名稱	材質	數量
1	BODY 本體	UPVC, CPVC, PP, PVDF	1
2	STEM O-RING 中心O環	EPDM, FPM	2
3	STEM 中心柱	UPVC, CPVC, PP, PVDF	1
4	BALL 球體	UPVC, CPVC, PP, PVDF	1
5	SEAT 墊座	PTFE	2
6	CARRIER O-RING 內特普O環	EPDM, FPM	1
7	SEAL CARRIER 內特普	UPVC, CPVC, PP, PVDF	1
8	UNION O-RING 由令O環	EPDM, FPM	2
9	END CONNECTOR 外特普	UPVC, CPVC, PP, PVDF	2
10	UNION NUT 螺帽	UPVC, CPVC, PP, PVDF	2
11	HANDLE 把手	ABS	1
12	INSERTED NUT 本體埋銅	C3602	2,4
13	SEAT O-RING 墊座O環	EPDM, FPM	2
14	HANDLE COVER 把手蓋	ABS	1

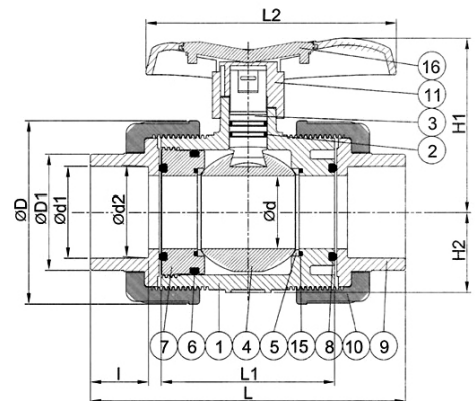
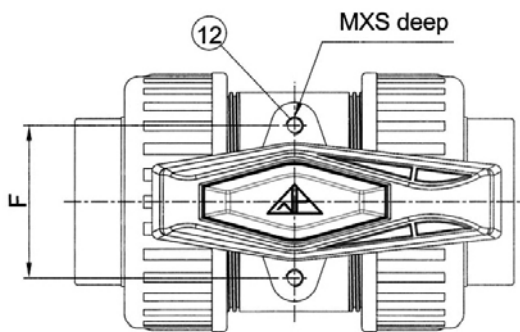

牌 價 (單位 / 元)

品號		VP-640		VP-641		VP-643	VP-644	
材質		UPVC		CPVC		PVDF	PP	
O環		EPDM	FPM	EPDM	FPM	FPM	EPDM	FPM
接口		插管 / 牙口						
1/2"	15A	160	297	284	420	1374	203	330
3/4"	20A	213	396	386	566	1917	288	458
1"	25A	341	638	590	884	2617	427	704
1-1/4"	32A	480	891	918	1326	3194	608	992
1-1/2"	40A	618	1155	1236	1768	4673	832	1333
2"	50A	917	1804	1677	2562	6554	1088	1920
2-1/2"	65A	1706	2816	2833	3922	11069	2340	3328
3"	80A	3370	5346	5372	7298	16258	4544	6357
4"	100A	6272	8723	9770	12092	34502	7115	9301

Nom.		SIZE	15mm (1/2")	20mm (3/4")	25mm (1")	32mm (1-1/4")	40mm (1-1/2")	50mm (2")	65mm (2-1/2")	80mm (3")	100mm (4")
JIS	d1		22.3	26.3	32.33	38.43	48.46	60.56	76.6	89.6	114.7
	d2		21.7	25.7	31.67	37.57	47.54	59.44	75.87	88.83	113.77
	l		22.22	25.4	28.58	31.75	34.93	38.1	61	63	69
ANSI	d1	UPVC	21.54	26.87	33.65	42.42	48.56	60.63	73.38	89.31	114.76
		CPVC								89.28	114.73
	d2	UPVC	21.23	26.57	33.27	42.04	48.11	60.17	72.85	88.7	114.1
		CPVC								88.67	114.04
	l		22.22	25.4	28.58	31.75	34.93	38.1	44.45	47.63	57.15
DIN	d1		20.3	25.3	32.3	40.3	50.3	63.3	75.35	90.5	110.6
	d2		19.9	24.9	31.9	39.9	49.9	62.9	74.9	89.9	109.9
	l		16	19	22	26	31	38	44	51	61
thd./in	NPT		14	14	11.5	11.5	11.5	11.5	8	8	8
	BSPT		14	14	11	11	11	11	11	11	11
	D		46.3	55.5	66.5	82	98.5	120	140	163	225
	D1		31.3	37.3	44.8	53.8	64	78	91.5	107.5	145.5
	d		13	18	23	30	38	48	61	68.5	99
	L		114	135	149	170	176	207	275	304	332
	L1		60	73	79	88	95	114	138	158	176
	L2		77	95	110	127	143	164	180	225	250.5
	H1		46	57	70	75	94	113	127.5	145	182
	H2		21	26	33	39	41	53	-	-	-
	F		30	33	40	47	52	70	-	-	-
	M		M5	M6	M6	M8	M8	M8	-	-	-
	S		8	8	11	11	11	15	-	-	-

VP-640F 雙邊由令球閥(法蘭) Double Flange Ball Valve



UPVC



CPVC



PP

- 工作壓力：150 PSI @73.4°F(23°C)
- 標準流量設計
- 雙由令設計可同時當由令及閥門使用
- 墊座鬆緊可做適度調整
- 不須使用特殊工具即可快速裝配
- 可埋入銅柱加裝自動控制器
- 標準品未埋入銅柱
- 適用於各規格、材質結合
- 另有彩色把手(紅 / 黃 / 藍 / 綠)供選購

品號	尺寸	規格	材質	墊座	O環	接口
VP-640 F	1/2"~4"	ANSI, JIS, DIN	UPVC	PTFE	EPDM, FPM	Flanged
VP-641 F	1/2"~4"	ANSI, JIS, DIN	CPVC	PTFE	EPDM, FPM	Flanged
VP-643 F	1/2"~4"	ANSI, JIS, DIN	PVDF	PTFE	FPM	Flanged
VP-644 F	1/2"~4"	ANSI, JIS, DIN	PP	PTFE	EPDM, FPM	Flanged

編號	零件名稱	材質	數量
1	BODY 本體	UPVC, CPVC, PP, PVDF	1
2	STEM O-RING 中心O環	EPDM, FPM	2
3	STEM 中心柱	UPVC, CPVC, PP, PVDF	1
4	BALL 球體	UPVC, CPVC, PP, PVDF	1
5	SEAT 墊座	PTFE	2
6	CARRIER O-RING 內特普O環	EPDM, FPM	1
7	SEAL CARRIER 內特普	UPVC, CPVC, PP, PVDF	1
8	UNION O-RING 由令O環	EPDM, FPM	2
9	UNION NUT 螺帽	UPVC, CPVC, PP, PVDF	2
10	HANDLE 把手	ABS, PP, PP+GF	1
11	INSERTED NUT 本體埋銅	C3604	2,4
12	FLANGE 法蘭片	UPVC, CPVC, PP, PVDF	2
13	SET RING 卡環	UPVC, CPVC, PP, PVDF	2
14	SEAT O-RING 墊座O環	EPDM, FPM	2
15	HANDLE COVER 把手蓋	ABS	1

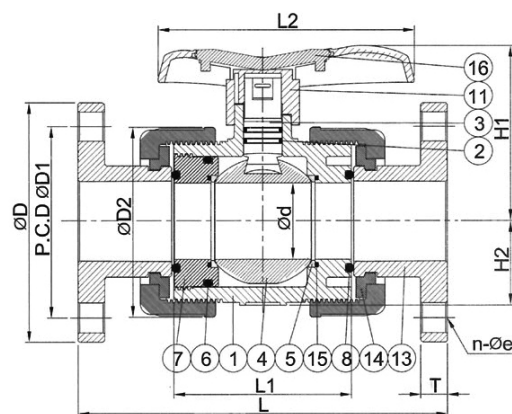
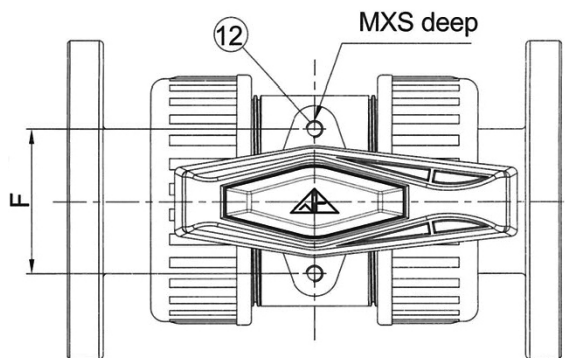

P.20

牌 價 (單位 / 元)

品號		VP-640 F		VP-641 F		VP-643 F	VP-644 F	
材質		UPVC		CPVC		PVDF	PP	
O環		EPDM	FPM	EPDM	FPM	FPM	EPDM	FPM
接口		法蘭						
1/2"	15A	256	396	431	567	2120	331	473
3/4"	20A	341	528	590	770	2960	448	638
1"	25A	544	847	930	1224	3890	704	1012
1-1/4"	32A	768	1188	1609	2017	4750	1002	1430
1-1/2"	40A	1013	1562	1983	2516	7210	1301	1859
2"	50A	1354	2255	2810	3695	9730	1792	2706
2-1/2"	65A	2560	3696	4363	5451	15450	3242	4400
3"	80A	5002	7029	6925	8851	22850	5461	7502
4"	100A	8160	10670	10483	12806	37500	8533	11055

*大型尺寸可訂製

Nom.	SIZE	15mm	20mm	25mm	32mm	40mm	50mm	65mm	80mm	100mm	
		(1/2")	(3/4")	(1")	(1-1/4")	(1-1/2")	(2")	(2-1/2")	(3")	(4")	
JIS	D	95	100	125	135	140	155	175	185	210	
	D1	70	75	90	100	105	120	140	150	175	
	L	143	172	187	190	212	234	259	304	372	
	n-øe	4-Ø15	4-Ø15	4-Ø19	4-Ø19	4-Ø19	4-Ø19	4-Ø19	4-Ø19	8-Ø19	8-Ø19
	T	13	15	15	16	16	16.5	18	19	19	19
ANSI	D	89	98	108	117	127	152	178	191	229	
	D1	61	70	79	89	99	121	140	152	191	
	L	143	172	187	190	212	234	259	304	372	
	n-øe	4-Ø16	4-Ø16	4-Ø16	4-Ø16	4-Ø16	4-Ø19	4-Ø19	4-Ø19	8-Ø19	8-Ø19
	T	13	15	15	16	17	17	18	19	20	20
DIN	D	95	105	115	140	150	165	185	200	220	
	D1	65	75	85	100	110	125	145	160	180	
	L	130	150	160	180	200	230	290	310	350	
	n-øe	4-Ø14	4-Ø14	4-Ø14	4-Ø18	4-Ø18	4-Ø18	4-Ø18	8-Ø18	8-Ø18	
	T	18.5	20	20	20	20	22	22.5	22.5	24	24
D2	46.3	55.5	66.5	82	98.5	120	140	163	163	225	
d	13	18	23	30	38	48	61	68.5	68.5	99	
L1	60	73	79	88	95	114	138	158	158	176	
L2	77	95	110	127	143	164	180	225	225	250.5	
H1	46	57	70	75	94	113	127.5	145	145	182	
H2	21	26	33	39	41	53	-	-	-	-	
F	30	33	40	47	52	70	-	-	-	-	
M	M5	M6	M6	M8	M8	M8	-	-	-	-	
S	8	8	11	11	11	15	-	-	-	-	

VP-710 法蘭式隔膜閥 Diaphragm Valve (Flanged)



UPVC



CPVC



PVDF

- 工作壓力：1/2"~3" 150PSI · 4"~6" 72PSI · 8" 43PSI@73.4°F(23°C)
- 關閉程度可清楚於透明罩上顯示
- 膜片可替換 · 保養管理容易
- 可調整的阻擋螺帽設計 · 可以防止關閉時手輪之壓力過當
- 法蘭片底部有平面設計 · 便於安裝及放置
- 中心柱及套筒可選用SUS 304 / 316 材質

品號	尺寸	規格	材質	墊片	隔膜片	接口	螺栓
VP-710	1/2"~8"	ANSI, JIS, DIN	UPVC	EPDM	EPDM, FPM, PTFE	Flanged	SUS 304 / 316
VP-711	1/2"~8"	ANSI, JIS, DIN	CPVC	EPDM	EPDM, FPM, PTFE	Flanged	SUS 304 / 316
VP-713	1/2"~8"	ANSI, JIS, DIN	PVDF	EPDM	EPDM, FPM, PTFE	Flanged	SUS 304 / 316
VP-714	1/2"~8"	ANSI, JIS, DIN	PP	EPDM	EPDM, FPM, PTFE	Flanged	SUS 304 / 316

編號	零件名稱		材質	數量
1	BODY	本體	UPVC, CPVC, PVDF, PP	1
2	BONNET	上蓋	UPVC, CPVC, PVDF, PP, PP+GF	1
3	COMPRESSOR	壓縮體	PP+GF, PVDF	1
4	HANDWHEEL	把手輪	PP	1
5	SLEEVE	中心套筒	C3602, SUS	1
6	STEM	中心柱	C3602, SUS	1
7	DIAPHRAGM	隔膜片	EPDM, FPM, PTFE	1
8	CAP	迫緊螺帽	UPVC, CPVC, PVDF, PP, PP+GF	1
9	COMPRESSOR PIN	彈簧銷	SUS304	1
10	INSERTED METAL	膜片螺絲	C3602, SUS	1
11	GREASE NIPPLE	黃油嘴	C3602 2-1/2"~8"	1
12	BOLT&WASHER	螺絲組	SUS304, SUS316	1/2"~3/4"-----4 SET 1"~2"-----6 SET
13	INSERTED NUT	本體埋銅	C3602, SUS304 SUS316	2-1/2"~4"-----8 SET 6"-----12 SET
14	NUT&WASHER	螺帽組	SUS304, SUS316	8"-----16 SET
15	THRUST RING & BEARING	薄片&止推軸承	PTFE 1-1/2"~3", SUS 4"~8"	1
16	STOPPER	阻擋螺帽	SUS304	1
17	SET NUT	固定螺帽	SUS304	1
18	GAUGE COVER	透明罩	AS	1
19	SHEET GASKET	墊片	EPDM	1
20	SHEET RING	中心平華司	SUS304	1
21	INDICATIVE WASHER	指示華司	ABS	1
22	O-RING	上蓋O環	NBR	1
23	NAME PLATE	銘牌	UPVC	1
24	PRESSURE PLATE	壓板	SUS304	1~6
25	CASING	套管	UPVC, CPVC, PVDF, PP 8" only	1

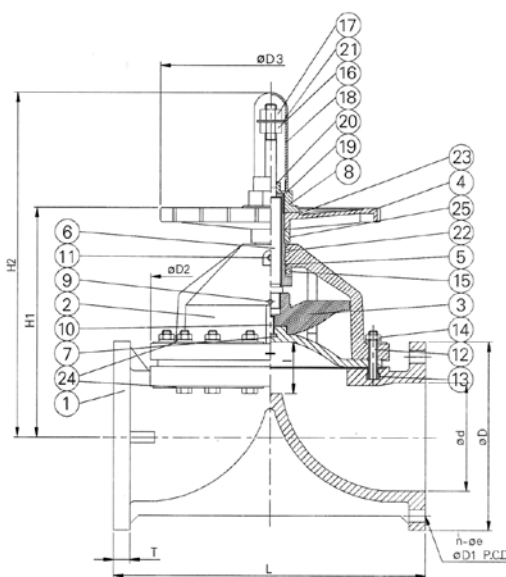

牌 價 (單位 / 元)

品號		VP-710			VP-711			VP-713		VP-714		
材質		UPVC			CPVC			PVDF		PP		
隔膜片		EPDM	FPM	PTFE	EPDM	FPM	PTFE	FPM	PTFE	EPDM	FPM	PTFE
接口		法蘭										
1/2"	15A	1020	2170	1840	2240	4590	3400	5000	3570	1400	2620	2220
3/4"	20A	1220	2520	2140	2680	5410	4010	5940	4240	1650	3030	2570
1"	25A	1500	3050	2590	3300	6600	4890	8320	5950	2120	3780	3210
1-1/2"	40A	2200	4430	3700	4400	9460	7010	12730	8840	2700	5020	4260
2"	50A	2860	5860	4970	5660	13230	9800	15690	11370	3860	7040	5970
2-1/2"	65A	5660	10780	9140	10500	22950	17000	24960	18080	7300	12260	10390
3"	80A	6540	13010	11030	12600	25380	18800	31550	22860	8500	15320	12990
4"	100A	9610	21110	16240	16500	29700	22000	46260	33040	12380	24270	18670
6"	150A	22000	53520	41170	33800	78300	58000	106950	76390	27520	60870	46830
8"	200A	42140	67780	52140	63500	108140	80100	198080	141490	52630	81840	62960

Nom.	SIZE	15mm	20mm	25mm	32mm	40mm	50mm	65mm	80mm	100mm	125mm	150mm	200mm
		(1/2")	(3/4")	(1")	(1-1/4")	(1-1/2")	(2")	(2-1/2")	(3")	(4")	(5")	(6")	(8")
JIS	D	95	100	125	140	140	155	175	185	210	250	280	343
	D1	70	75	90	100	105	120	140	150	175	210	240	290
	n-øe	4-Ø15	4-Ø15	4-Ø19	4-Ø19	4-Ø19	4-Ø19	4-Ø19	8-Ø19	8-Ø19	8-Ø23	8-Ø23	12-Ø23
	L	110	120	130	180	180	210	250	280	340	410	480	570
ANSI	D	89	98	108	127	127	152	178	191	229	250	279	343
	D1	61	70	79	89	99	121	140	152	191	216	241	299
	n-øe	4-Ø16	4-Ø16	4-Ø16	4-Ø16	4-Ø16	4-Ø19	4-Ø19	4-Ø19	8-Ø19	8-Ø23	8-Ø23	8-Ø23
	L	108	150	150	176	176	202	250	264	329	410	480	570
DIN	D	95	105	115	150	150	165	185	200	220	250	285	343
	D1	65	75	85	100	110	125	145	160	180	210	240	295
	n-øe	4-Ø14	4-Ø14	4-Ø14	4-Ø18	4-Ø18	4-Ø18	4-Ø18	8-Ø18	8-Ø18	8-Ø18	8-Ø22	8-Ø22
	L	130	150	160	200	200	230	290	310	350	410	480	570
JIS	UPVC, CPVC	12	13	13	16	16	20	22	22	22	24	25	30
	PP, PVDF	12	13	13	16	16	20	23	22	22	25	25	30
ANSI	UPVC, CPVC	13	15	13	17	17	17	20	20	22	24	25	30
	PP, PVDF	13	15	13	18	18	18	21	20	22	25	25	30
DIN	UPVC, CPVC	20	20	20	20	20	22	22	24	24	24	25	30
	PP, PVDF	20	20	20	20	20	22	22	24	24	25	25	30
D2		54X70	63X78	63X88	125	125	148	182	203	255	330	392	432
D3		95	95	110	150	150	150	210	210	250	405	405	405
d		13	18	25	41	41	52	67	78	100	125	148	198
H1		85	94	98	130	130	148	189	250	275	334	334	450
H2		130	137	160	200	200	225	268	343	383	476	476	627
l		10	12	15	22	22	31	39	48	60	70	70	95

小叮嚀：

1. 安裝使用中，應常檢視中心柱上端開度指示螺帽組需保持無鬆動狀態
2. 手輪正常旋緊至無法繼續時即代表閥門已完全關閉，切勿再強迫旋轉避免造成無法修復之膜片撕裂現象！

VP-730 由令式隔膜閥 Diaphragm Valve



UPVC



CPVC

- 工作壓力：100 PSI@73.4°F(23°C)
- 關閉程度可清楚於透明罩上顯示
- 膜片可替換，保養管理容易
- 可調整的阻擋螺帽設計，可以防止關閉時手輪之壓力過當
- 底端埋有銅柱，易於固定
- 中心柱及套筒可選用SUS304/316材質

品號	尺寸	規格	材質	墊座	O環	隔膜片	接口	螺栓
VP-730	1/2"~2"	ANSI, JIS, DIN, BS	UPVC	EPDM	EPDM, FPM	EPDM, FPM, PTFE	Socket, Threaded	SUS 304 /316
VP-731	1/2"~2"	ANSI, JIS, DIN, BS	CPVC	EPDM	EPDM, FPM	EPDM, FPM, PTFE	Socket, Threaded	SUS 304 /316
VP-733	1/2"~2"	ANSI, JIS, DIN, BS	PVDF	EPDM	EPDM, FPM	EPDM, FPM, PTFE	Socket, Threaded	SUS 304 /316
VP-734	1/2"~2"	ANSI, JIS, DIN, BS	PP	EPDM	EPDM, FPM	EPDM, FPM, PTFE	Socket, Threaded	SUS 304 /316

編號	零件名稱		材質	數量
1	BODY	本體	UPVC, CPVC, PVDF, PP	1
2	BONNET	上蓋	UPVC, CPVC, PVDF, PP, PP+GF	1
3	COMPRESSOR	壓縮體	PP+GF, PVDF	1
4	HANDWHEEL	把手輪	PP	1
5	SLEEVE	中心套筒	C3602, SUS	1
6	STEM	中心柱	C3602, SUS	1
7	DIAPHRAGM	隔膜片	EPDM, FPM, PTFE	1
8	CAP	迫緊螺帽	UPVC, CPVC, PVDF, PP, PP+GF	1
9	COMPRESSOR PIN	彈簧銷	SUS420	1
10	INSERTED METAL	膜片螺絲	SUS304	1
11	BOLT&WASHER	螺絲組	SUS304, SUS316	1/2"~3/4"---4 SET 1"~2"-----6 SET
12	INSERTED NUT	本體埋銅	C3602, SUS304 SUS316	
13	NUT&WASHER	螺帽組	SUS304, SUS316	
14	THRUST RING	薄片	PTFE 1-1/2"~2"	1
15	STOPPER	阻擋螺帽	SUS304	1
16	SET NUT	固定螺帽	SUS304	1
17	GAUGE COVER	透明罩	AS	1
18	SHEET GASKET	墊片	EPDM	1
19	SHEET RING	中心平華司	SUS304	1
20	INDICATIVE WASHER	指示華司	ABS	1
21	O-RING	上蓋O環	NBR	1
22	NAME PLATE	銘牌	UPVC	1
23	PRESSURE PLATE	壓板	SUS304	1~2
24	O-RING	由令O環	EPDM, FPM	2
25	END CONNECTOR	外特普	UPVC, CPVC, PVDF, PP	2
26	UNION NUT	螺帽	UPVC, CPVC, PVDF, PP	2

牌 價 (單位 / 元)

品號		VP-730			VP-731			VP-733		VP-734		
材質		UPVC			CPVC			PVDF		PP		
隔膜片		EPDM	FPM	PTFE	EPDM	FPM	PTFE	FPM	PTFE	EPDM	FPM	PTFE
接口		由令										
1/2"	15A	1173	2496	2134	2576	5279	3928	5750	4106	1610	3010	2570
3/4"	20A	1403	2898	2482	3082	6222	4634	6831	4876	1898	3485	2978
1"	25A	1725	3508	3038	3795	9900	5682	9568	6843	2438	4347	3748
1-1/2"	40A	2530	5095	4328	5060	10879	8132	14640	10166	3105	5773	4969
2"	50A	3289	6739	5811	6509	15215	11364	18044	13076	4439	8096	6957

Nom.	SIZE	15mm	20mm	25mm	40mm	50mm
		(1/2")	(3/4")	(1")	(1-1/2")	(2")
JIS	d1	22.3	26.3	32.33	48.46	60.56
	d2	21.7	25.7	31.67	47.54	59.44
	l	22.22	25.4	28.58	34.93	38.1
ANSI	d1	21.54	26.87	33.65	48.56	60.63
	d2	21.23	26.57	33.27	48.11	60.17
	l	22.22	25.4	28.58	34.93	38.1
DIN	d1	20.3	25.3	32.3	50.3	63.3
	d2	19.9	24.9	31.9	49.9	62.9
	l	16	19	22	31	38
BS	d1	21.7	27.15	33.95	48.65	60.75
	d2	21	26.35	33.15	47.85	59.95
	l	22.22	25.4	28.58	34.93	38.1
thd./in	NPT	14	14	11.5	11.5	11.5
	BSPT	14	14	11	11	11
D		46	55	66	97	120
D1		31	37	44	64	78
D2		95	95	110	150	150
d3		20	25	32	50	63
L2		130	150	160	200	230
L1		180	207	227	281	317
L		124	144	154	194	224
H2		128	138	144	220	225
H1		86	95	98	150	148
l1	PVC	16	19	22	31	34
	PP, PVDF	14.5	16	18	23.5	27.5
S		11	11	11	15	15
F		25	25	25	45	45
M		M6	M6	M6	M8	M8

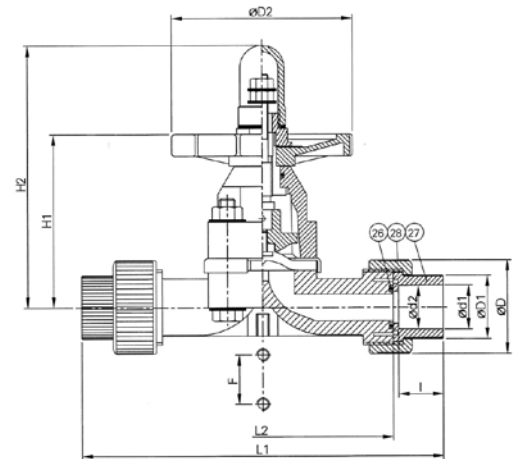
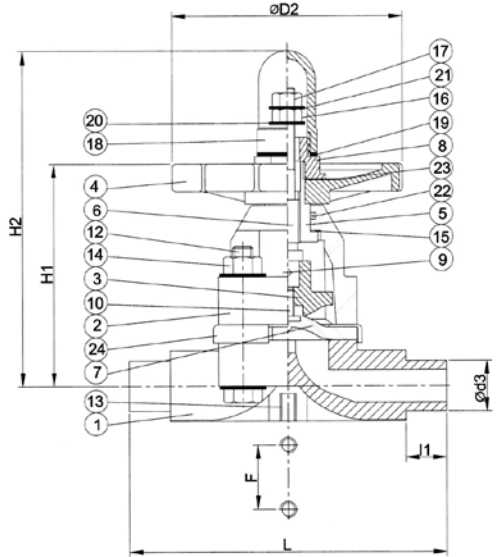

VP-810 把手式蝶閥 Butterfly Valve (Handle type)



UPVC



CPVC



PP

- 工作壓力：2"~8" 150 PSI 73.4°F(23°C)
(標準中心柱材質SUS 410 + 熱處理，亦可選用SUS 304/316 材質)
- 蝶片開啟角度可由刻度清楚顯示，並可由齒輪片固定
- 全面型墊片密閉設計，安全性佳

品號	尺寸	規格	材質	墊座	O環	蝶片	接口
VP-810	1-1/2"~8"	ANSI, JIS, DIN	UPVC	EPDM, FPM	EPDM, FPM	PP	Flanged
VP-811	1-1/2"~8"	ANSI, JIS, DIN	CPVC	EPDM, FPM	EPDM, FPM	CPVC	Flanged
VP-813	1-1/2"~8"	ANSI, JIS, DIN	PVDF	EPDM, FPM	EPDM, FPM	PVDF	Flanged
VP-814	1-1/2"~8"	ANSI, JIS, DIN	PP	EPDM, FPM	EPDM, FPM	PP	Flanged

編號	零件名稱		材質	數量
1	BODY	本體	UPVC, CPVC, PVDF, PP	1
2	DISC	閥門	UPVC, CPVC, PVDF, PP	1
3	SEAT	墊座	EPDM, FPM	1
4	STEM	中心柱	SUS	1
5	STEM O-RING	中心O環	EPDM, FPM	2
6	DISC O-RING	閥門O環	EPDM, FPM	2
7	INSERTED NUT	本體埋銅	C3604	3
8	LARGE HANDLE	把手	PP	1
9	SMALL HANDLE	小把手	PP	1
10	SPRING LOCK	把手蓋	PP	1
11	HANDLE INSERT	方型鐵	STAINLESS STEEL	1
12	HANDLE LEVER	鏈桿	SUS304	1
13	SPRING	彈簧	SUS304	1
14	SPRING PIN	彈簧銷	SUS304	1
15	SPRING PIN	彈簧銷	SUS304	1
16	WASHER	平華司	SUS304	1
17	LOCKING PLATE	齒輪片	SUS304	1
18	GEAR SEAT	齒輪座	UPVC, PVDF	1
19	STEM WASHER	平華司	SUS304	1
20	BOLT	齒輪螺絲	SUS304	3
21	NUT	塑膠螺帽	UPVC, PVDF	1
22	INSERTED NUT	螺帽埋銅	C3604	1
23	SCALE	刻度指示牌	SUS304	1
24	RIVET	鉚釘	SUS304	2

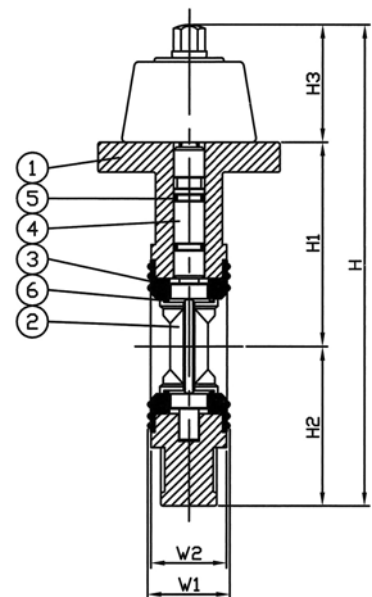

牌 價 (單位 / 元)

品號		VP-810		VP-811		VP-814	
材質		UPVC		CPVC		PP	
O環		EPDM	FPM	EPDM	FPM	EPDM	FPM
接口		法蘭					
1-1/2"	40A	4247	5887	7240	9142	5178	6435
2"	50A	4247	5887	7240	9142	5178	6435
2-1/2"	65A	4500	6492	7560	10400	5400	7409
3"	80A	5200	7540	8740	11428	6240	8537
4"	100A	6870	9390	10750	14285	8250	10086
5"	125A	10620	12857	13410	22857	12342	13578
6"	150A	12142	15714	16071	28571	14285	16785
8"	200A	18571	25000	25714	35714	21428	26428

Nom.	SIZE	40mm	50mm	65mm	80mm	100mm	125mm	150mm	200mm
		(1-1/2")	(2")	(2-1/2")	(3")	(4")	(5")	(6")	(8")
JIS	D1	105	120	140	150	175	210	240	290
	n-Øe	4-Ø19	4-Ø19	4-Ø19	8-Ø19	8-Ø19	8-Ø23	8-Ø23	12-Ø23
ANSI	D1	99	121	140	152	191	216	241	299
	n-Øe	4-Ø16	4-Ø19	4-Ø19	4-Ø19	8-Ø19	8-Ø23	8-Ø23	8-Ø23
DIN	D1	110	125	145	160	180	210	240	295
	n-Øe	4-Ø18	4-Ø18	4-Ø18	8-Ø18	8-Ø18	8-Ø18	8-Ø22	8-Ø22
D		148	165.5	185	200	229	257	288	343
D2		49.5	56.5	69.5	79.5	102.5	129.5	149.5	202
D3		99	106	119	124	134.5	164	170	201
L		199	199	199	199	252	297	297	297
H		233	248	267	278.5	318	374	407.5	467
H1		96	106	115	118	138.5	163.5	179	208.5
H2		74	82.75	92.5	100	114.5	128.5	144	171.5
H3		63	59.5	59.5	61	65.5	81.5	84.5	84.5
W1		39	42.5	47	47	57	68	70	85
W2		35.7	39	44	44	54	63	65	79
W3		90	94	94	94	99.5	110	101	122

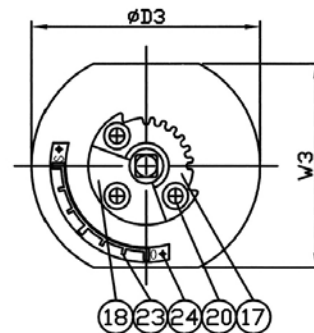
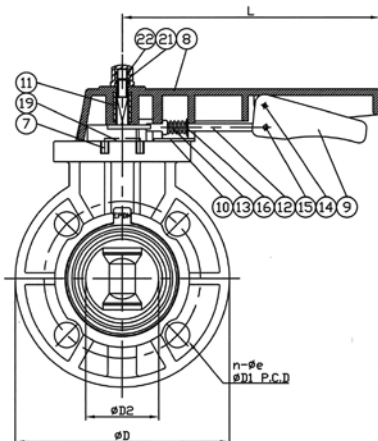

VP-820 齒輪式蝶閥 Butterfly Valve (Gear Box)



UPVC



CPVC



PP

- 工作壓力：2"~10" 150 PSI, 12" 100 PSI, 14", 16" 86 PSI, 18" 72 PSI, 20" ~ 24" 51 PSI@73.4°F(23°C)
(標準中心柱材質SUS 410+熱處理·亦可選用SUS 304/316) 低扭力·密閉效果佳
- 蝶片開啓角度可由箭頭指標清楚顯示

品號	尺寸	規格	材質	墊座	O環	蝶片	接口
VP-820	2"~24"	ANSI, JIS, DIN	UPVC	EPDM, FPM	EPDM, FPM	PP	Flanged
VP-821	2"~24"	ANSI, JIS, DIN	CPVC	EPDM, FPM	EPDM, FPM	CPVC	Flanged
VP-823	2"~24"	ANSI, JIS, DIN	PVDF	EPDM, FPM	EPDM, FPM	PVDF	Flanged
VP-824	2"~24"	ANSI, JIS, DIN	PP	EPDM, FPM	EPDM, FPM	PP	Flanged

編號	零件名稱		材質	數量
1	BODY	本體	UPVC, CPVC, PVDF, PP	1
2	DISC	閥門	UPVC, CPVC, PVDF, PP	1
3	SEAT	墊座	EPDM, FPM	1
4	STEM	中心柱	SUS	1
5	STEM O-RING	中心O環	EPDM, FPM	2
6	DISC O-RING	閥門O環	EPDM, FPM	2
7	HAND-WHEEL	把手輪	FC	1
8	GEAR BOX	齒輪箱	FC	1
9	BOLT & WASHER	螺絲組	SUS304	4
10	SPRING PIN	彈簧銷	SUS	1
11	PACKING	墊片	EPDM 6"~14"	1
12	SMALL HANDLE	小把手	STEEL 6"~24"	1
13	KEY	方鍵	SUS 6"~24"	1

牌 價 (單位 / 元)

品號		VP-820		VP-821		VP-824	
材質		UPVC		CPVC		PP	
O環		EPDM	FPM	EPDM	FPM	EPDM	FPM
接口		法蘭					
2"	50A	7963	9493	10756	12533	8603	9784
2-1/2"	65A	8200	10060	11056	13706	8812	10696
3"	80A	8853	11036	12156	14666	9600	11753
4"	100A	10413	12763	14033	17333	11484	13206
5"	125A	14580	16666	17183	26000	15946	17103
6"	150A	16000	19333	19666	31333	17768	20112
8"	200A	22666	33333	43333	49166	26666	40000
10"	250A	27666	51666	50000	80000	33333	60000
12"	300A	35333	73333	56666	91000	37333	80000
14"	350A	55200	91200	83900		65200	149463
16"	400A	82000	127778	121200		93700	169287
18"	450A	114800	172578	170000		125000	197249
20"	500A	126700	193367	199600		143200	234537
24"	600A	169200	280311	271400		204400	315038

*大型尺寸可訂製

Nom.		50mm (2")	65mm (2-1/2")	80mm (3")	100mm (4")	125mm (5")	150mm (6")	200mm (8")	250mm (10")	300mm (12")
JIS	D1	120	140	150	175	210	240	290	355	400
	n-øe	4-Ø19	4-Ø19	8-Ø19	8-Ø19	8-Ø23	8-Ø23	12-Ø23	12-Ø25	16-Ø25
ANSI	D1	121	140	152	191	216	241	299	362	432
	n-øe	4-Ø19	4-Ø19	4-Ø19	8-Ø19	8-Ø23	8-Ø23	8-Ø23	12-Ø25	12-Ø25
DIN	D1	125	145	160	180	210	240	295	350	400
	n-øe	4-Ø18	4-Ø18	8-Ø18	8-Ø18	8-Ø18	8-Ø22	8-Ø22	12-Ø22	12-Ø22
D		165.5	185	200	229	257	288	343	411	490
D2		56.5	69.5	79.5	102.5	129.5	149.5	201.5	255	311
D3		159	159	159	159	159	202	202	202	250
H		289	307.5	310	352.5	396.5	464	524	588	709
H1		127	135.5	138	158.5	196.5	221	253.5	283.5	340
H2		105	113.5	116	136.5	163.5	177	209.5	239.5	298
H3		53	53	53	53	75	77.5	77.5	77.5	78
L1		140	140	140	140	140	284.5	284.5	284.5	330
L2		39	44	44	54	63	65	79	104	127
L3		42.5	47	47	57	68	70	85	109	131.5
L4		41.5	41.5	41.5	41.5	41.5	60	60	60	60
L5		121	121	121	121	121	161	161	161	185

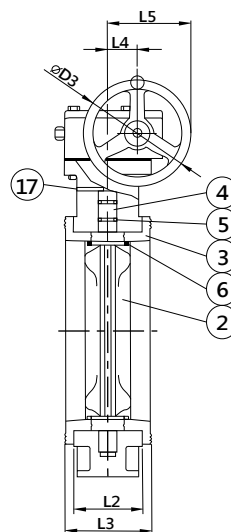
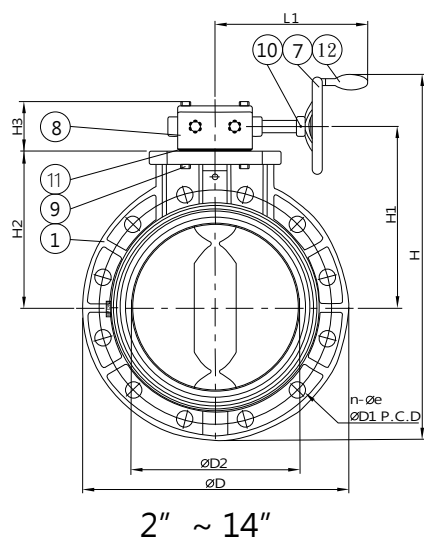

VP-900/910 球閥(經濟型) Compact Ball Valve



UPVC



CPVC

- 工作壓力 : 150 PSI @73.4°F(23°C)
- 流量損失小
- 操作方便 · 使用成本低廉

品號	尺寸	規格	材質	墊座	O環	接口
VP-900	3/8"~2"	ANSI, JIS, DIN, BS	UPVC	PTFE	EPDM, FPM	Socket, Threaded
VP-901	3/8"~2"	ANSI, JIS, DIN, BS	CPVC	PTFE	EPDM, FPM	Socket, Threaded
VP-910	3/8"~4"	ANSI, JIS, DIN, BS	UPVC	EPDM	EPDM, FPM	Socket, Threaded
VP-911	3/8"~2"	ANSI, JIS, DIN, BS	CPVC	EPDM	EPDM, FPM	Socket, Threaded
VP-915	1/2"~2"	ANSI, JIS, DIN, BS	ABS	EPDM	EPDM, FPM	Socket, Threaded

編號	零件名稱	材質	數量
1	BODY	本體 UPVC, CPVC, ABS	1
2	SEAT	墊座 EPDM, PTFE	2
3	BALL	球體 UPVC, CPVC, ABS, PP	1
4	O-RING	O環 EPDM, FPM	1
5	HANDLE	把手 ABS	1
6	BOLT	螺絲 ZINC-PLATED STEEL	1
7	CAP	把手蓋 ABS	1
8	ZINC-PLATED INSERTED	鍍鋅柱 ZINC-PLATED STEEL 2-1/2"~4"	1

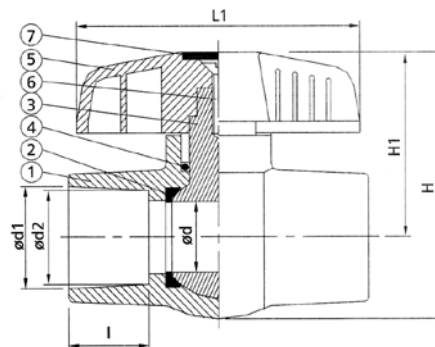
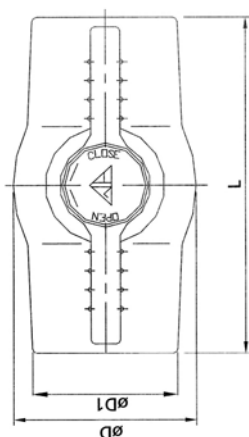

牌 價 (單位 / 元)

品號		VP-900	VP-901	VP-910	VP-911
材質		UPVC	CPVC	UPVC	CPVC
墊座		PTFE		EPDM	VT
接口		插管 / 牙口			
3/8"	10A	71		71	
1/2"	15A	50	127	50	127
3/4"	20A	70	151	70	151
1"	25A	90	218	90	218
1-1/4"	32A	125	278	125	278
1-1/2"	40A	180	453	180	453
2"	50A	230	591	230	591
2-1/2"	65A	612		612	
3"	80A	1047		1047	
4"	100A	1987		1987	

Nom.		SIZE	10mm (3/8")	15mm (1/2")	20mm (3/4")	25mm (1")	32mm (1-1/4")	40mm (1-1/2")	50mm (2")	65mm (2-1/2")	80mm (3")	100mm (4")
JIS	d1		18.4	22.3	26.3	32.33	38.43	48.46	60.56	76.6	89.6	114.7
	d2		17.78	21.7	25.7	31.67	37.57	47.54	59.44	75.87	88.83	113.77
ANSI	d1	UPVC	17.45	21.54	26.87	33.65	42.42	48.56	60.63	73.38	89.31	114.76
		CPVC									89.28	114.73
	d2	UPVC	17.04	21.23	26.57	33.27	42.04	48.11	60.17	72.85	88.7	114.1
		CPVC									88.67	114.04
DIN	d1		16.3	20.3	25.3	32.3	40.3	50.3	63.3	75.30	90.5	110.6
	d2		15.9	19.9	24.9	31.9	39.9	49.9	62.9	74.9	89.9	109.9
BS	d1		17.5	21.7	27.15	33.95	42.65	48.65	60.75	75.75	89.35	114.95
	d2		16.8	21	26.35	33.15	41.85	47.85	59.95	74.95	88.45	113.65
I	DIN		14	16	19	22	26	31	38	44	51	61
	ANSI, JIS		19.05	22.22	25.4	28.58	31.75	34.93	38.1	44.45	47.63	57.15
thd. /in.	BSPT		19	14	14	11	11	11	11	11	11	11
	NPT		18	14	14	11.5	11.5	11.5	11.5	8	8	8
D			31	38	49	57	63	75	92	110	133	170
D1			24	30	38	45	54	62	77	92	106	135
d			12	14	20	25	30	36	46.5	58	77	98
L			68	83	95	106	114	130	147	204	229	300
L1			60	70	88	100	100	109	134	178	224	276
H			49	64	79	95	99	115	135	160	190	233
H1			34	45	54	65	67	76	89	105	124	148

VP-240 由令 Unions



UPVC



CPVC



PP

- 拆裝容易可適用於各種規格與材質之管路

品號	尺寸	規格	材質	O環	接口
VP-240	1/2"~4"	ANSI, JIS, DIN, BS	UPVC	EPDM, FPM	Socket, Threaded
VP-241	1/2"~4"	ANSI, JIS, DIN, BS, CTS	CPVC	EPDM, FPM	Socket, Threaded
VP-243	1/2"~4"	ANSI, JIS, DIN, BS	PVDF	FPM	Socket, Threaded
VP-244	1/2"~4"	ANSI, JIS, DIN, BS	PP	EPDM, FPM	Socket, Threaded

編號	零件名稱		材質	數量
1	BODY	本體	UPVC, CPVC, PP, PVDF	1
2	END CONNECTOR	外特普	UPVC, CPVC, PP, PVDF	1
3	UNION NUT	螺帽	UPVC, CPVC, PP, PVDF	1
4	O-RING	本體O環	EPDM, FPM	1

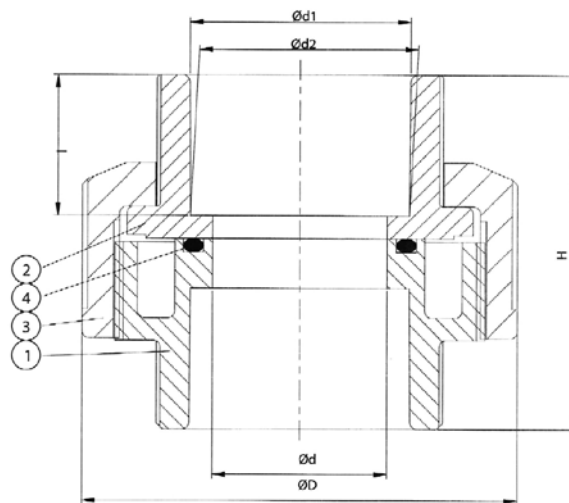

牌 價 (單位 / 元)

品號		VP-240	VP-241	VP-243	VP-244
材質		UPVC	CPVC	PVDF	PP
O環		EPDM/FPM	EPDM/FPM	FPM	EPDM/FPM
接口		插管/牙口			
1/2"	15A	76	104	329	84
3/4"	20A	96	160	482	108
1"	25A	124	264	543	144
1-1/4"	32A	156	344	1071	220
1-1/2"	40A	204	440	1346	266
2"	50A	284	504	2282	432
2-1/2"	65A	488	832	3304	746
3"	80A	648	1248	4832	914
4"	100A	1336	2136	11236	2195

Nom.		SIZE	15mm (1/2")	20mm (3/4")	25mm (1")	32mm (1-1/4")	40mm (1-1/2")	50mm (2")	65mm (2-1/2")	80mm (3")	100mm (4")
JIS	d1		22.3	26.3	32.33	38.43	48.46	60.56	76.6	89.6	114.7
	d2		21.7	25.7	31.67	37.57	47.54	59.44	75.87	88.83	113.77
	l		22.2	25.4	28.58	31.75	34.93	38.1	44.45	47.63	69
ANSI	d1	UPVC	21.54	26.87	33.65	42.42	48.56	60.63	73.38	89.31	114.76
		CPVC								89.28	114.73
	d2	UPVC	21.23	26.57	33.27	42.04	48.11	60.17	72.85	88.7	114.1
		CPVC								88.67	114.04
		l		22.22	25.4	28.58	31.75	34.93	38.1	44.45	47.63
DIN	d1		20.3	25.3	32.3	40.3	50.3	63.3	75.35	90.5	110.6
	d2		19.9	24.9	31.9	39.9	49.9	62.9	74.9	89.9	109.9
	l		16	19	22	26	31	38	44	51	61
BS	d1		21.7	27.15	33.95	42.65	48.65	60.75	75.75	89.35	114.95
	d2		21	26.35	33.15	41.85	47.85	59.95	74.95	88.45	113.65
	l		22.22	25.4	28.58	31.75	34.93	38.1	44.45	47.63	57.15
thd./in.	NPT		14	14	11.5	11.5	11.5	11.5	8	8	8
	BSPT		14	14	11	11	11	11	11	11	11
	D		46.5	55	66	82	98	120	140	163	225
	d		13.5	16.5	22	30	38	48	63	75	100
	H		56	64	72	87	90	98	114	127	162

VP-250 盲法蘭 Blind Flanges



UPVC



CPVC

- 規格：JIS 10K / ANSI 150 LBS / DIN PN10@73.4°F(23°C), 適用墊片接合型式
- 適用於管線末端止水、暫時收尾

品號	尺寸	規格	材質	接口
VP-250	1/2"~12"	ANSI, JIS, DIN	UPVC	Flanged
VP-251	1/2"~12"	ANSI, JIS, DIN	CPVC	Flanged

Nom.		SIZE	15mm (1/2")	20mm (3/4")	25mm (1")	32mm (1-1/4")	40mm (1-1/2")	50mm (2")	65mm (2-1/2")
ANSI	D		89	98	108	117	127	152	178
	D1		61	70	79	89	98	121	140
	T		12	13	14	16	17.5	19	22
	n-øe		4-Ø16	4-Ø16	4-Ø16	4-Ø16	4-Ø16	4-Ø19	4-Ø19
JIS	D		95	100	125	135	140	155	175
	D1		70	75	90	100	105	120	140
	T		14	16	16	18	18	20	22
	n-øe		4-Ø15	4-Ø15	4-Ø19	4-Ø19	4-Ø19	4-Ø19	4-Ø19

Nom.		SIZE	80mm (3")	100mm (4")	125mm (5")	150mm (6")	200mm (8")	250mm (10")	300mm (12")
ANSI	D		191	229	254	284	343	406	481
	D1		152	191	216	241	299	362	432
	T		24	24	28	26	28	34	34
	n-øe		4-Ø19	8-Ø19	8-Ø23	8-Ø23	8-Ø23	12-Ø25	12-Ø25
JIS	D		185	210	250	280	330	400	445
	D1		150	175	210	240	290	355	400
	T		22	22	24	26	28	31	34
	n-øe		8-Ø19	8-Ø19	8-Ø23	8-Ø23	12-Ø23	12-Ø25	16-Ø25

牌 價 (單位 / 元)

品號		VP-250	VP-251
材質		UPVC	CPVC
接口		ANSI / JIS	
1/2"	15A	47	152
3/4"	20A	61	184
1"	25A	84	248
1-1/4"	32A	105	364
1-1/2"	40A	115	400
2"	50A	136	592
2-1/2"	65A	210	924
3"	80A	262	1168
4"	100A	378	1440
5"	125A	525	2056
6"	150A	842	2840
8"	200A	1350	4400
10"	250A	2346	9000
12"	300A	2671	10000

*大型尺寸可訂製

BLIND FLANGE

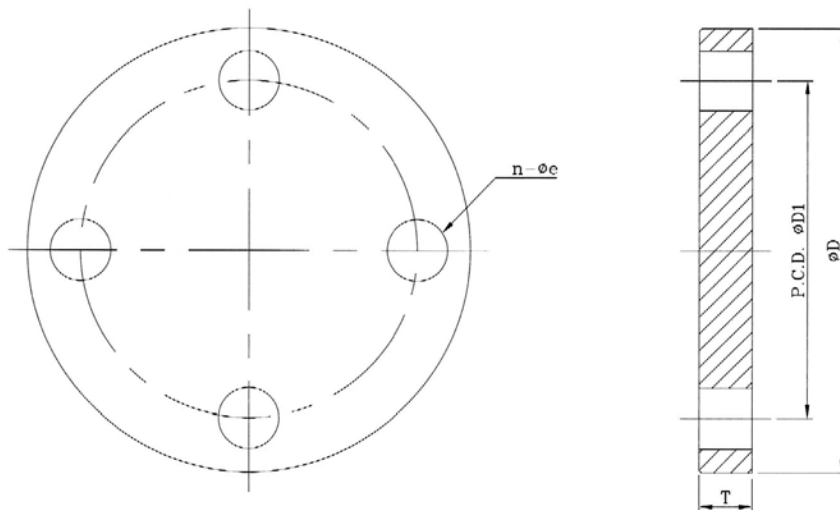

VP-260 單片式法蘭

One-piece(TS) Flanges



UPVC



CPVC



PP

- 規格：JIS 10K/ANSI 150 LBS/ DIN PN10@73.4°F(23°C), 適用墊片接合型式
- 適用於法蘭式、異種材質銜接
- 適用於美、日規管路轉換

品號	尺寸	規格	材質	接口
VP-260	1/2"~12"	ANSI, JIS, DIN	UPVC	Socket, Threaded / Flanged
VP-261	1/2"~12"	ANSI, JIS, DIN	CPVC	Socket, Threaded / Flanged
VP-264	1/2"~12"	ANSI, JIS, DIN	PP	Socket, Threaded / Flanged

ANSI 150 PSI

Nom.	SIZE	15mm (1/2")	20mm (3/4")	25mm (1")	32mm (1-1/4")	40mm (1-1/2")	50mm (2")	65mm (2-1/2")	80mm (3")	100mm (4")	125mm (5")	150mm (6")	200mm (8")
D		89	98	108	117	127	152	178	191	229	254	280	342
D1		61	70	79	89	98	121	140	152	191	216	241	299
D2		33	40	48	57	65	78	92	109	139	167	186	255
d		15	25	31	40	46	57.5	70	78	111.5	136	146	209
d1	UPVC	21.54	26.87	33.65	42.42	48.56	60.63	73.38	89.31	114.76	141.81	168.83	219.84
	CPVC								89.28	114.73			
d2	UPVC	21.23	26.57	33.27	42.04	48.11	60.17	72.85	88.7	114.1	141	168	218.7
	CPVC								88.67	114.04	141.05		
H		25	29	31.7	35	38	41.3	47.6	50.8	61	82.5	142	131
T		11	12	14	16	17.5	19	22	23.5	24	28.5	25.5	28
l		22.22	25.4	28.58	31.75	34.93	38.1	44.45	47.63	57.15	66.7	132	102
n-øe		4-Ø16	4-Ø16	4-Ø16	4-Ø16	4-Ø16	4-Ø19	4-Ø19	4-Ø19	4-Ø19	8-Ø23	8-Ø23	8-Ø23

JIS 10K

Nom.	SIZE	10mm (3/8")	15mm (1/2")	20mm (3/4")	25mm (1")	32mm (1-1/4")	40mm (1-1/2")	50mm (2")	65mm (2-1/2")	80mm (3")	100mm (4")	125mm (5")	150mm (6")	200mm (8")	250mm (10")	300mm (12")
D		90	95	100	125	135	140	155	175	185	210	250	280	330	404	445
D1		65	70	75	90	100	105	120	140	150	175	210	240	290	355	400
D2		26	31	35	42.5	48.5	61	73	90	105	132	158	189	244	289	344
d		15	18	22	25	30	41	52	67	78	100	125	146	196	243	298
d1		18.4	22.4	26.45	32.55	38.6	48.7	60.8	76.6	89.6	114.7	140.8	166	217.5	267.7	318.7
H		30	35	40	46	50.5	61.5	71	70	73	93	114	142	161	167	167
T		14	14	15	15	16	16	20	22	22	22	24	26	29	30	30
l		26	30	35	40	44	55	63	61	64	84	104	128	149	155	156
n-øe		4-Ø15	4-Ø15	4-Ø15	4-Ø19	4-Ø19	4-Ø19	4-Ø19	4-Ø19	8-Ø19	8-Ø19	8-Ø23	8-Ø23	12-Ø23	12-Ø25	16-Ø25
1/T		1/30	1/34	1/34	1/34	1/34	1/37	1/37	1/48	1/49	1/56	1/58	1/63	1/50	1/55	1/55

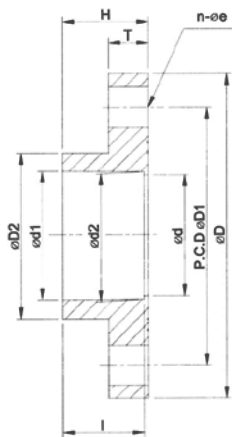

ANSI 150 PSI / DIN PN10

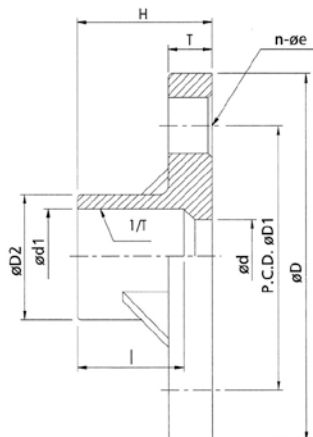

JIS 10K

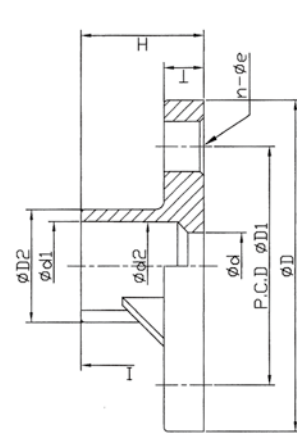

A+J 10K

牌 價 (單位 / 元)

品號		VP-260	VP-261	VP-264
材質		UPVC	CPVC	PP
接口		ANSI / JIS / A+J	ANSI / A+J	JIS
1/2"	15A	53	152	54
3/4"	20A	67	184	70
1"	25A	94	248	96
1-1/4"	32A	117	364	120
1-1/2"	40A	126	400	132
2"	50A	150	592	156
2-1/2"	65A	232	924	240
3"	80A	288	1168	300
4"	100A	416	1440	432
5"	125A	578	2100	600
6"	150A	927	2840	960
8"	200A	1485	4400	1543
10"	250A	2582	8210	2681
12"	300A	2938	9350	3053

*UPVC 單片法蘭10" 接口僅有JIS及A+J | CPVC 單片法蘭10" 接口僅有A+J

A+J 10K

SIZE Nom.	15mm (1/2")	20mm (3/4")	25mm (1")	32mm (1-1/4")	40mm (1-1/2")	50mm (2")	65mm (2-1/2")	80mm (3")	100mm (4")	125mm (5")	150mm (6")	200mm (8")	250mm (10")	300mm (12")	
D	96.5	100	125.5	135.5	140.5	155	175.5	186	210	249	280	329.5	404.5	445	
D1	70	75	90	100	105	120	140	150	175	210	240	290	355	400	
D2	31.5	35	45	54	61.5	74	92.5	106	132	159	186	238	289	341	
d	14.5	22	30	30	41	53	65	78	100	127	146	196	250	298	
d1	UPVC	21.54	26.87	33.65	42.42	48.56	60.63	73.38	89.31	114.76	141.81	168.83	219.84	273.81	324.61
	CPVC								89.28	114.73					
d2	UPVC	21.23	26.57	33.27	42.04	48.11	60.17	72.85	88.70	114.07	141	168	218.7	272.67	323.47
	CPVC								88.67	114.04					
H	35	40.5	46.5	51	61.5	70	69	73.5	93	115.5	142	160	167.5	167	
T	14	15	15	16	16	20	22	22	22	24	26	29	30	30	
l	31	35.5	40.5	44.5	55	65	61	64	86	100.5	132	145	155	155	
n-øe	4-Ø15	4-Ø15	4-Ø19	4-Ø19	4-Ø19	4-Ø19	4-Ø19	8-Ø19	8-Ø19	8-Ø23	8-Ø23	12-Ø23	12-Ø25	16-Ø25	

DIN PN10

SIZE Nom.	DN15 (1/2")	DN20 (3/4")	DN25 (1")	DN32 (1-1/4")	DN40 (1-1/2")	DN50 (2")	DN65 (2-1/2")	DN80 (3")	DN100 (4")	DN125 (5")	DN150 (6")	DN200 (8")	DN250 (10")	DN300 (12")
D	95	105	115	140	150	164	185	200	220	254	280	340	396	445
D1	65	75	85	100	110	125	145	160	180	210	240	295	350	400
D2	28	33	41	50	61	76	90	108	131	167	186	255	290	362
d	16	21	28	36	45	57	69.5	82	103	136	146.5	215	240	303
d1	20.3	25.3	32.3	40.3	50.3	63.3	75.35	90.5	110.6	140.85	160.85	226.25	251.45	316.85
d2	19.9	24.9	31.9	39.9	49.9	62.9	74.9	89.9	109.9	140.05	160.05	225.05	250.05	315.05
H	24	21.5	24.5	28	33.5	41	46	55	65	82.5	141.5	131	149	182
T	12	14	14	14	16	16	16	18	18	28.5	25.5	28	31	33
l	21	19	22	26	31	38	43.5	50.5	60.5	77	132	119	131	164
n-øe	4-Ø14	4-Ø14	4-Ø14	4-Ø18	4-Ø18	4-Ø18	4-Ø18	8-Ø18	8-Ø18	8-Ø23	8-Ø23	8-Ø23	12-Ø23	12-Ø23

VP-270 兩片式法蘭

Tow-piece (Van Stone) Flanges



UPVC



CPVC

- 規格：ANSI 150 LBS適用墊片接合型式
- 適用於法蘭式、異種材質銜接
- 適用於美、日規管路轉換
- 提升大尺寸施工方便性

品號	尺寸	規格	材質	接口
VP-270	1/2"~24"	ANSI	UPVC	Socket, Threaded / Flanged
VP-271	1/2"~24"	ANSI	CPVC	Socket, Threaded / Flanged

SIZE Nom.	15mm	20mm	25mm	32mm	40mm	50mm	65mm	80mm	100mm	125mm	
	(1/2")	(3/4")	(1")	(1-1/4")	(1-1/2")	(2")	(2-1/2")	(3")	(4")	(5")	
D	89	98	108	117	128	152	178	192	229	250	
D1	61	70	79	89	98	121	140	152	191	216	
D2	31	37	44.5	54	64.5	76	92	109	133	161.44	
d	12.5	16.5	22	29	37.8	51	68	77	102	125	
d1	UPVC	21.54	26.87	33.65	42.42	48.56	60.63	73.38	89.31	114.76	141.81
	CPVC								89.28	114.73	
d2	UPVC	21.23	26.57	33.27	42.04	48.11	60.17	72.85	88.7	114.1	141
	CPVC								88.67	114.04	141.05
H	26	30	34.5	39.5	39.5	43	49	54	64	90.5	
T	11	12	14	16	18	20	24	26	28	28.5	
l	22.22	25.4	28.58	31.75	34.93	38.1	44.45	47.63	57.15	66.7	
n-øe	4-Ø16	4-Ø16	4-Ø16	4-Ø16	4-Ø16	4-Ø19	4-Ø19	4-Ø19	8-Ø19	8-Ø23	

SIZE Nom.	150mm	200mm	250mm	300mm	350mm	400mm	450mm	500mm	600mm	
	(6")	(8")	(10")	(12")	(14")	(16")	(18")	(20")	(24")	
D	283	343	406	481	533	600	635	699	813	
D1	241	299	362	432	476	540	578	635	749	
D2	192	246	298	348	395	452	507	564	675	
d	156	204	256	307	340	384	430	481	590	
d1	UPVC	168.83	219.84	273.81	324.61	356.49	407.54	458.6	509.65	611.52
	CPVC									
d2	UPVC	168	218.7	272.67	323.47	355.22	405.89	456.69	507.49	608.84
	CPVC									
H	85	118	150	191	195	220	280	310	346	
T	32	36	42	42	50.8	60	62	63	72	
l	76.2	102	127	165	161	204	254	280	305	
n-øe	8-Ø23	8-Ø23	12-Ø25	12-Ø25	12-Ø29	16-Ø32	16-Ø32	20-Ø32	20-Ø35	

牌價 (單位 / 元)

品號		VP-270	VP-271
材質		UPVC	CPVC
接口		ANSI	
1/2"	15A	74	152
3/4"	20A	97	184
1"	25A	132	248
1-1/4"	32A	168	364
1-1/2"	40A	181	400
2"	50A	192	592
2-1/2"	65A	300	924
3"	80A	328	1168
4"	100A	438	1440
5"	125A	778	2328
6"	150A	974	2840
8"	200A	1560	4400
10"	250A	2710	8210
12"	300A	3086	9350

*大型尺寸可訂製

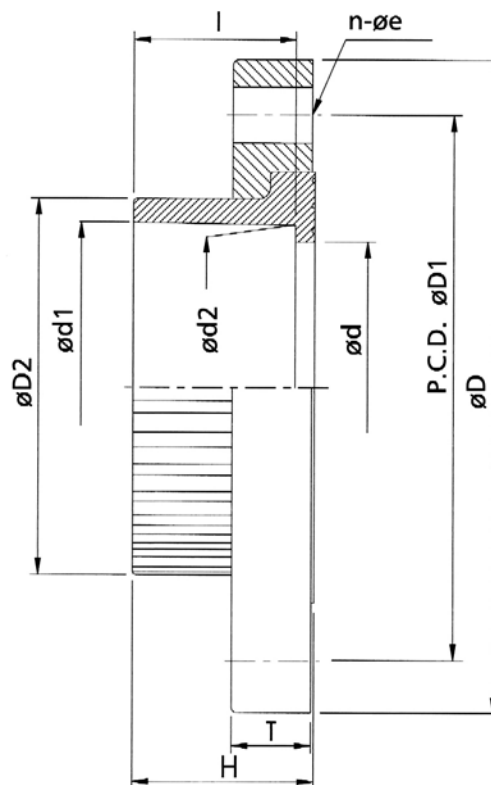

VP-289 橡膠墊片

Rubber Gaskets



EPDM



FPM



EPDM+PTFE

- 材質：EPDM, FPM, EPDM+PTFE
- 提高法蘭接觸面之密封度，以防滲漏

品號	尺寸	規格	材質
VP-289	1/2"~ 12"	ANSI, JIS, DIN	EPDM, FPM, *EPDM+PTFE

*EPDM+PTFE非鑽琪品牌

ANSI 150 PSI

SIZE Nom.	15mm (1/2")	20mm (3/4")	25mm (1")	32mm (1-1/4")	40mm (1-1/2")	50mm (2")	65mm (2-1/2")	80mm (3")	100mm (4")	125mm (5")
D	86.36	96.52	106.68	114.30	124.40	149.86	175.20	187.96	226.06	251.46
D1	61	70	79	89	98	121	140	152	191	216
D2	40.64	48.26	53.34	66.04	68.55	83.82	101.60	111.76	137.16	165.10
D3	25.40	33.02	38.10	50.80	53.34	68.58	86.36	99.06	119.38	144.78
d	17.78	22.86	30.48	38.10	43.18	53.34	68.58	81.28	101.60	127.00
n-øe	4-Ø16	4-Ø16	4-Ø16	4-Ø16	4-Ø16	4-Ø19	4-Ø19	4-Ø19	8-Ø19	8-Ø23
T	3	3	3	3	3	3	3	3	3	3

SIZE Nom.	150mm (6")	200mm (8")	250mm (10")	300mm (12")	350mm (14")	400mm (16")	450mm (18")	500mm (20")	600mm (24")
D	276.86	340.36	403.86	480.06	530	595	630	692	800
D1	241	299	362	432	476	540	578	635	749
D2	190.50	246.38	307.34	356.06	405	482	510	566	674
D3	167.64	215.90	269.24	325.20	380	452	472	535	644
d	148.86	198.12	248.92	299.72	350	400	450	500	600
n-øe	8-Ø23	8-Ø23	12-Ø25	12-Ø25	12-Ø29	16-Ø29	16-Ø32	20-Ø32	20-Ø35
T	3	3	3	3	3	3	5	5	5

JIS 10K

SIZE Nom.	15mm (1/2")	20mm (3/4")	25mm (1")	32mm (1-1/4")	40mm (1-1/2")	50mm (2")	65mm (2-1/2")	80mm (3")	100mm (4")	125mm (5")	150mm (6")	200mm (8")	250mm (10")	300mm (12")	350mm (14")	400mm (16")
D	93	98	123	133	138	153	173	183	208	248	278	328	398	443	485	560
D1	70	75	90	100	105	120	140	150	175	210	240	290	355	400	445	510
D2	41	47	53	65	69	83	101	112	138	166	190	247	306	352	405	482
D3	26	32	38	50	54	68	86	98	120	145	168	216	270	324	380	452
d	18	22	30	37	43	54	69	80	102	127	150	198	249	300	350	400
n-øe	4-Ø15	4-Ø15	4-Ø19	4-Ø19	4-Ø19	4-Ø19	4-Ø19	8-Ø19	8-Ø19	8-Ø23	8-Ø23	12-Ø23	12-Ø25	16-Ø25	16-Ø25	16-Ø27
T	3	3	3	3	3	3	3	3	3	3	3	3	3	3	3	3

牌 價 (單位 / 元)

品號		VP-289		
材質		EPDM	FPM	EPDM+PTFE
接口		ANSI / JIS / DIN		
1/2"	15A	20	262	202
3/4"	20A	24	304	264
1"	25A	30	396	285
1-1/4"	32A	34	491	331
1-1/2"	40A	42	529	331
2"	50A	53	713	417
2-1/2"	65A	60	816	477
3"	80A	67	958	538
4"	100A	87	1136	789
5"	125A	127	1422	966
6"	150A	154	2333	1072
8"	200A	184	3076	
10"	250A	300	3751	
12"	300A	400	4200	
14"	350A	1020		
16"	400A	1200		
18"	450A	1500		
20"	500A	2760		
24"	600A	3333		

*大型尺寸可訂製

DIN PN 10

SIZE Nom.	15mm (1/2")	20mm (3/4")	25mm (1")	32mm (1-1/4")	40mm (1-1/2")	50mm (2")	65mm (2-1/2")	80mm (3")	100mm (4")	125mm (5")	150mm (6")	200mm (8")	250mm (10")	300mm (12")
D	93	103	113	133	148	163	183	198	218	248	283	338	393	443
D1	65	75	85	100	110	125	145	160	180	210	240	295	350	400
D2	41	47	53	65	69	83	101	112	138	166	190	247	306	352
D3	26	32	38	50	54	68	86	98	120	145	168	216	270	324
d	18	22	30	37	43	54	69	80	102	127	150	198	249	300
n-øe	4-Ø14	4-Ø14	4-Ø14	4-Ø18	4-Ø18	4-Ø18	4-Ø18	8-Ø18	8-Ø18	8-Ø18	8-Ø22	8-Ø22	12-Ø22	12-Ø22
T	3	3	3	3	3	3	3	3	3	3	3	3	3	3

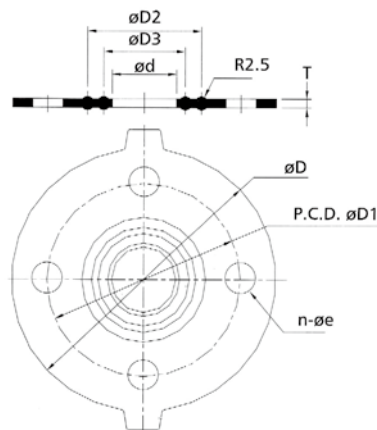

SCH 80/40 厚管 Pipe



SCH80 厚管

Nom. SIZE	1/2"	3/4"	1"	1-1/4"	1-1/2"	2"	2-1/2"	3"	4"	5"
D (mm)	21.34	26.67	33.40	42.16	48.26	60.33	73.03	88.90	114.30	141.30
Tolerance	±0.10	±0.10	±0.13	±0.13	±0.15	±0.15	±0.18	±0.20	±0.23	±0.25
t(min)	3.73	3.91	4.55	4.85	5.08	5.54	7.01	7.62	8.56	9.52
Tolerance	+0.51	+0.51	+0.53	+0.58	+0.61	+0.66	+0.84	+0.91	+1.02	+1.14

Nom. SIZE	6"	8"	10"	12"	14"	16"	18"	20"	24"	
D (mm)	168.28	219.08	273.05	323.85	355.60	406.40	457.20	508.00	609.60	
Tolerance	±0.28	±0.38	±0.38	±0.38	±0.38	±0.48	±0.48	±0.58	±0.79	
t(min)	10.97	12.70	15.06	17.45	19.05	21.41	23.80	26.20	30.94	
Tolerance	+1.32	+1.52	+1.80	+2.08	+2.29	+2.57	+2.84	+3.15	+3.71	

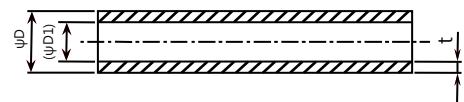

SCH40 厚管

Nom. SIZE	1/2"	3/4"	1"	1-1/4"	1-1/2"	2"	2-1/2"	3"	4"	5"
D (mm)	21.34	26.67	33.40	42.16	48.26	60.33	73.03	88.90	114.30	141.30
Tolerance	±0.10	±0.10	±0.13	±0.13	±0.15	±0.15	±0.18	±0.20	±0.23	±0.25
t(min)	2.77	2.87	3.38	3.56	3.68	3.91	5.16	5.49	6.02	6.55
Tolerance	+0.51	+0.51	+0.51	+0.51	+0.51	+0.51	+0.61	+0.66	+0.71	+0.79

Nom. SIZE	6"	8"	10"	12"	14"	16"	18"	20"	24"	
D (mm)	168.28	219.08	273.05	323.85	355.60	406.40	457.20	508.00	609.60	
Tolerance	±0.28	±0.38	±0.38	±0.38	±0.38	±0.48	±0.48	±0.58	±0.79	
t(min)	7.11	8.18	9.27	10.31	11.10	12.70	14.27	15.06	17.45	
Tolerance	+0.86	+0.99	+1.12	+1.24	+1.35	+1.52	+1.70	+1.80	+2.08	

牌價 (單位：米 / 元)

品號	厚管								
	UPVC		CPVC		材質	UPVC		CPVC	
規格	SCH80	SCH40	SCH80	SCH40	規格	SCH80	SCH40	SCH80	SCH40
1/2"	57	52	188	160	6"	1476	1129	5044	3668
3/4"	77	69	255	212	8"	2238	1695	8817	6293
1"	113	102	375	313	10"	3379	2448	15988	10762
1-1/4"	156	139	516	422	12"	4646	3235	21980	14217
1-1/2"	187	163	627	504	14"	6361	3652	28230	14613
2"	259	219	868	676	16"	8173	9571	32928	24620
2-1/2"	416	362	1323	1066	18"	11345	10753	43786	26830
3"	528	450	1773	1395	20"	14733	13265	58221	34250
4"	773	641	2592	1987	24"	23773	19027	82600	47678
5"	1232	997	4606	2829					

*大型尺寸可訂製

SCH 80 90° 彎頭

90° Elbow



彎頭 (Slip x Slip)

Nom. SIZE	1/2"	3/4"	1"	1-1/4"	1-1/2"	2"	2-1/2"	3"	4"	5"	6"	8"	10"	12"	14"
D0(mm)	31.50	38.00	46.00	55.00	62.00	75.00	90.00	107.00	133.00	163.50	191.00	246.00	306.50	364.00	396.50
d1	21.54	26.87	33.66	42.42	48.56	60.63	73.38	89.31	114.76	141.81	168.83	219.84	273.81	324.61	356.49
d2	21.23	26.57	33.27	42.04	48.11	60.17	72.85	88.70	114.07	141.05	168.00	218.69	272.67	323.47	355.22
l	22.22	25.40	28.58	31.75	34.93	38.10	44.45	47.63	57.15	66.68	76.20	101.60	127.00	152.40	*180.00
d	16.50	22.00	28.00	35.00	43.00	54.00	69.00	84.00	105.00	136.00	150.00	200.00	265.00	315.00	346.00
G	12.80	15.30	18.00	23.00	26.00	32.00	38.00	48.00	59.00	80.00	89.00	115.00	150.00	180.00	

*該項未參照ASTM標準

龍口彎 (Slip x NPT)

Nom. SIZE	1/2"	3/4"	1"	1-1/4"	1-1/2"	2"
D0(mm)	30.50	38.00	46.00	55.00	60.00	75.00
d1	21.54	26.87	33.65	42.42	48.56	60.63
d2	21.23	26.57	33.27	42.04	48.11	60.17
l	22.22	25.40	28.58	31.75	34.93	38.10
d	16.00	22.00	28.00	35.00	43.00	54.00
NPT (thd./in)	14.0	14.0	11.5	11.5	11.5	11.5

Slip x NPT

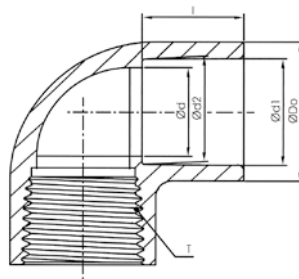

Slip x Slip

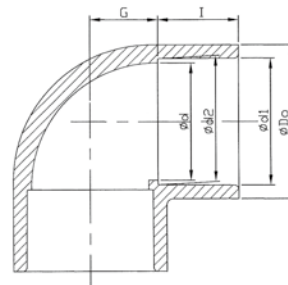

NPTx NPT

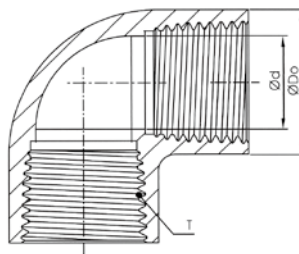

雙內牙彎頭 (NPT x NPT)

Nom. SIZE	1/2"	3/4"	1"	1-1/4"	1-1/2"	2"
D0(mm)	30.50	38.00	46.00	55.00	60.00	75.00
d	16.00	22.00	28.00	35.00	43.00	54.00
NPT (thd./in)	14.0	14.0	11.5	11.5	11.5	11.5

牌價 (單位 / 元)

品號	90° 彎頭												
	UPVC			CPVC			UPVC			CPVC			
材質	SXS	SXT	TXT	SXS	SXT	TXT	材質	SXS	SXT	TXT	SXS	SXT	TXT
接口							接口						
1/2"	47	146	146	86	179	179	4"	668			2372		
3/4"	60	176	176	109	232	232	5"	1736			3755		
1"	97	202	202	173	313	313	6"	1901			4765		
1-1/4"	129	226	226	375	523	523	8"	5239			11662		
1-1/2"	138	291	291	418	675	675	10"	31259			41554		
2"	167	355	355	506	883	883	12"	40749			56220		
2-1/2"	391			1163			14"	58325			95023		
3"	440			1317									

*S為平口、T為牙口 | 大型尺寸可訂製

SCH 80 45° 彎頭

45° Elbow



Nom. SIZE	1/2"	3/4"	1"	1-1/4"	1-1/2"	2"	2-1/2"	3"
D0(mm)	30.50	40.00	46.00	56.00	62.50	75.50	90.00	107.00
d1	21.54	26.87	33.66	42.42	48.56	60.63	73.38	89.31
d2	21.23	26.57	33.27	42.04	48.11	60.17	72.85	88.70
l	22.22	25.40	28.58	31.75	34.93	38.10	44.45	47.63
d	16.50	22.00	28.00	35.00	43.00	54.00	69.00	84.00
J	6.50	8.00	8.00	10.00	12.00	16.00	18.00	20.00

Nom. SIZE	4"	5"	6"	8"	10"	12"	14"	
D0(mm)	133.00	163.5	191.0	246.0	307.0	364.0	396.5	
d1	114.76	141.81	168.83	219.84	273.81	324.61	356.49	
d2	114.07	141.05	168.00	218.69	272.67	323.47	355.22	
l	57.15	66.68	76.20	101.60	127.00	152.40	*180.00	
d	108.00	136.0	150.0	200.0	265.0	315.0	350.0	
J	26.00	38.50	45.00	51.00	60.00	73.00		

*該項未參照ASTM標準

牌 價 (單位 / 元)

品號	45°彎頭						
	UPVC		CPVC		CPVC		
材質	UPVC		CPVC		材質	UPVC	CPVC
接口	SXS		SXS		接口	SXS	
1/2"	89	104			4"	1814	1959
3/4"	134	151			5"	2211	3833
1"	202	240			6"	2284	6037
1-1/4"	257	472			8"	4952	12559
1-1/2"	304	485			10"	20787	31776
2"	394	544			12"	26814	55905
2-1/2"	828	1111			14"	43230	73490
3"	1007	1428					

*S為平口、T為牙口 | 大型尺寸可訂製

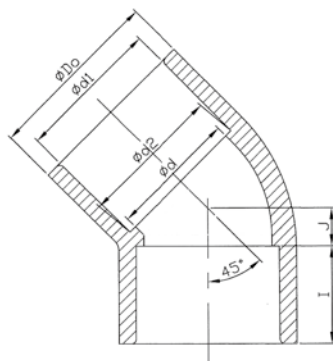

SCH 80 直接頭 Coupling



Slip x Slip

Nom. SIZE	1/2"	3/4"	1"	1-1/4"	1-1/2"	2"	2-1/2"	3"	4"	5"	6"	8"	10"	12"	14"	16"
D0(mm)	30.50	38.00	46.00	55.50	61.00	73.50	89.00	106.0	133.0	163.0	191.0	246.0	307.0	364.0	396.5	454.0
d1	21.54	26.87	33.66	42.42	48.56	60.63	73.38	89.31	114.76	141.81	168.83	219.84	273.81	324.61	356.49	407.54
d2	21.23	26.57	33.27	42.04	48.11	60.17	72.85	88.70	114.07	141.05	168.00	218.69	272.67	323.47	355.22	405.89
l	22.22	25.40	28.58	31.75	34.93	38.10	44.45	47.63	57.15	66.68	76.20	101.60	127.00	152.40	205.00	230.00
d	16.50	22.00	28.00	35.00	42.50	54.00	65.00	80.00	100.0	134.5	158.0	200.0	259.0	308.0	346.0	396.0
L	50.00	63.50	70.00	75.00	77.00	84.00	100.0	108.0	126.0	160.0	169.0	220.0	283.0	336.5	436.5	486.5

Slip x NPT

Nom. SIZE	1/2"	3/4"	1"	1-1/4"	1-1/2"	2"	2-1/2"	3"	4"
D0(mm)	30.50	38.00	46.00	55.50	61.00	73.50	89.00	106.00	133.00
d1	21.54	26.87	33.65	42.42	48.56	60.63	73.38	89.31	114.76
d2	21.23	26.57	33.27	42.04	48.11	60.17	72.85	88.70	114.07
l	22.22	25.40	28.58	31.75	34.93	38.10	44.45	47.63	57.15
d	16.50	22.00	28.00	35.00	42.50	54.00	65.00	80.00	100.00
L	50.00	63.50	70.00	75.00	77.00	84.00	100.00	108.00	126.00
NPT (thd./in)	14.0	14.0	11.5	11.5	11.5	11.5			

Slip x Slip

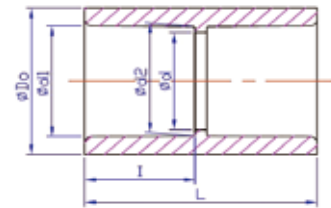

Slip x NPT

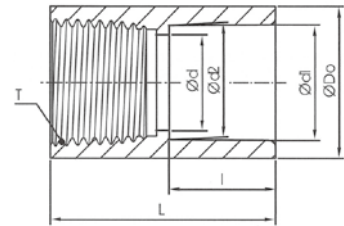

NPT x NPT

Nom. SIZE	1/2"	3/4"	1"	1-1/4"	1-1/2"	2"	2-1/2"	3"	4"
D0(mm)	30.50	38.00	46.00	55.50	61.00	73.50	89.00	106.00	133.00
d	16.50	22.00	28.00	35.00	42.50	54.00	65.00	80.00	100.00
L	50.00	63.50	70.00	75.00	77.00	84.00	100.00	108.00	126.00
NPT (thd./in)	14.0	14.0	11.5	11.5	11.5	11.5			

NPT x NPT

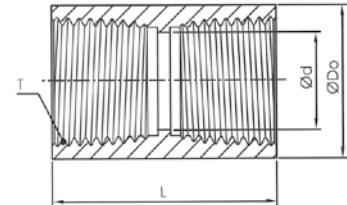

牌 價 (單位 / 元)

品號	直接頭												
	UPVC			CPVC									
材質	UPVC			CPVC			材質	UPVC			CPVC		
接口	SXS	SXT	TXT	SXS	SXT	TXT	接口	SXS	SXT	TXT	SXS	SXT	TXT
1/2"	85	105	130	90	146	146	4"	736	1838		1182	4800	
3/4"	115	145	170	126	154	154	5"	1382			2578		
1"	118	200	225	170	357	357	6"	1583	2355		2784		
1-1/4"	180	281	281	255	365	365	8"	2154			7519		
1-1/2"	194	345	345	321	425	425	10"	4851			16000		
2"	207	419	419	378	603	603	12"	5591			23500		
2-1/2"	511	950	950	830	1406		14"	14300			24310		
3"	587	1069		902	2884		16"	17000			28900		

*S為平口、T為牙口 | 大型尺寸可訂製

SCH 80 三通 Tee



Slip x Slip x Slip

Nom. SIZE	1/2"	3/4"	1"	1-1/4"	1-1/2"	2"	2-1/2"	3"	4"	5"	6"	8"	10"	12"	14"
D0(mm)	30.00	37.50	46.00	55.50	62.00	75.00	90.00	109.0	135.0	163.5	191.0	246.0	317.0	364.0	396.5
d1	21.54	26.87	33.66	42.42	48.56	60.63	73.38	89.31	114.76	141.81	168.83	219.84	273.81	324.61	356.5
d2	21.23	26.57	33.27	42.04	48.11	60.17	72.85	88.70	114.07	141.05	168.0	218.69	272.67	323.47	355.2
l	22.22	25.40	28.58	31.75	34.93	38.10	44.45	47.63	57.15	66.68	76.20	101.6	127.0	152.4	*180.0
d	16.50	24.00	28.00	35.00	41.00	52.00	69.00	84.00	109.0	136.0	150.0	200.0	265.0	315.0	346.0
L	73.00	89.50	103.0	119.5	132.0	152.0	173.0	197.0	239.0	298.0	336.5	439.0	560.0	660.0	856.5
H	37.25	42.50	48.00	57.75	64.00	73.00	86.50	98.50	119.5	149.0	168.25	219.5	280.0	330.0	428.2

*該項未參照ASTM標準

Slip x NPT x Slip

Nom. SIZE	1/2"	3/4"	1"	1-1/4"	1-1/2"	2"
D0(mm)	30.00	37.50	46.00	55.50	62.00	75.00
d1	21.54	26.87	33.65	42.42	48.56	60.63
d2	21.23	26.57	33.27	42.04	48.11	60.17
l	22.22	25.40	28.58	31.75	34.93	38.10
d	16.50	24.00	28.00	35.00	41.00	52.00
L	73.00	89.50	103.0	119.5	132.0	152.0
NPT (thd./in)	14.0	14.0	11.5	11.5	11.5	11.5

Slip x NPT x Slip

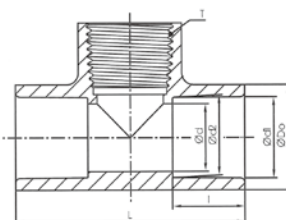

Slip x Slip x Slip



NPT x NPT x NPT

Nom. SIZE	1/2"	3/4"	1"	1-1/4"	1-1/2"	2"
D0(mm)	30.00	37.50	46.00	55.50	62.00	75.00
d	16.50	24.00	28.00	35.00	41.00	52.00
L	73.00	89.50	103.0	119.5	132.0	152.0
NPT (thd./in)	14.0	14.0	11.5	11.5	11.5	11.5

NPT x NPT x NPT

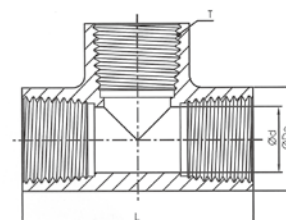

牌價 (單位 / 元)

品號	三通					
	UPVC			CPVC		
材質	SXSXS	SXTXS	TXTXT	SXSXS	SXTXS	TXTXT
1/2"	132	180	180	128	420	420
3/4"	138	220	220	204	642	642
1"	173	345	345	250	691	691
1-1/4"	475	710		527	710	710
1-1/2"	475	760	760	604	730	730
2"	594	950	950	673	811	811
2-1/2"	646			1712		3978
3"	808			1712		4626
接口	SXSXS	SXTXS	TXTXT	SXSXS	SXTXS	TXTXT
4"	936			2279		10960
5"	2944			5312		
6"	3196			5930		
8"	7413			16989		
10"	32654			44813		
12"	46116			69256		
14"	105250			178924		

*S為平口、T為牙口 | 大型尺寸可訂製

SCH 80 十字通 / 異徑十字通 Cross / Reducer Cross



十字通

Nom. SIZE	1/2"	3/4"	1"	1-1/4"	1-1/2"	2"	2-1/2"	3"	4"	6"
D0(mm)	30.50	42.00	47.00	55.00	62.00	75.00	89.00	105.0	132.0	191.0
d1	21.54	26.87	33.66	42.42	48.56	60.63	73.38	89.31	114.76	168.83
d2	21.23	26.57	33.27	42.04	48.11	60.17	72.85	88.70	114.07	168.0
l	22.22	25.40	28.58	31.75	34.93	38.10	44.45	47.63	57.15	76.2
d	16.50	22.00	28.00	35.00	43.00	54.00	65.00	80.00	100.0	150.0
L	74.50	86.00	104.0	116.0	128.5	146.0	171.0	196.0	236.5	336.4

異徑十字通

Nom. SIZE	1"*3/4"	1-1/2"*1"	2"*1"	4"*2"
D1(mm)	35.00	44.00	44.00	73.00
d1	26.87	33.66	33.66	60.63
d2	26.57	33.27	33.27	60.17
l1	25.40	28.58	28.58	38.10
D2	44.00	60.00	73.00	132.0
d3	33.66	48.56	60.63	114.76
d4	33.27	48.11	60.17	114.07
l2	28.58	34.93	38.10	57.15
d	22.00	28.00	28.00	54.00
d0	28.00	43.00	54.00	100.0
L1	90.00	111.0	121.0	194.0
L2	97.20	128.0	145.7	238.3

牌價 (單位 / 元)

品號	十字通	
材質	UPVC	CPVC
接口	S	
1/2"	685	792
3/4"	685	900
1"	802	997
1-1/4"	962	912
1-1/2"	1038	912
2"	1284	1504
2-1/2"	1751	2005
3"	2184	2554
4"	3800	4563
5"		
6"	17800	19178
8"	33440	
10"	63044	80441

十字通

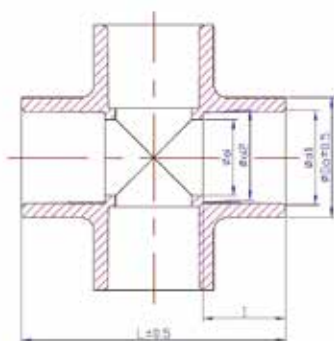

異徑十字通

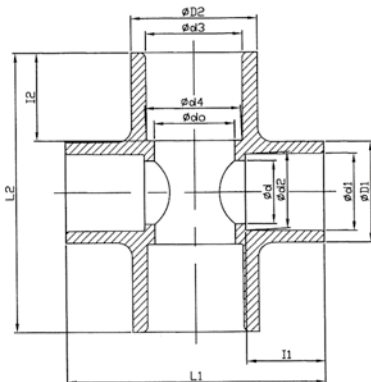

*S為平口、T為牙口 | 大型尺寸可訂製

品號	異徑十字通	
材質	UPVC	CPVC
接口	S	
1"*3/4"	975	1292
1-1/2"*1"	1400	1648
2"*1"	1795	2715
4"*2"	5730	7085

SCH 80 管帽 Cap



Nom. SIZE	1/2"	3/4"	1"	1-1/4"	1-1/2"	2"	2-1/2"	3"
D0(mm)	30.5	37.0	45.5	55.0	61.5	75.0	91.0	106.0
d1	21.54	26.87	33.66	42.42	48.56	60.63	73.38	89.31
d2	21.23	26.57	33.27	42.04	48.11	60.17	72.85	88.70
l	22.22	25.40	28.58	31.75	34.93	38.10	44.45	47.63
L	31.0	36.0	41.0	46.0	50.0	55.5	65.5	69.5

Nom. SIZE	4"	5"	6"	8"	10"	12"	14"	16"
D0(mm)	134.0	163.5	192.0	246.0	307.0	366.0	395.0	452.0
d1	114.76	141.81	168.83	219.84	273.81	324.61	356.49	407.54
d2	114.07	141.05	168.00	218.69	272.67	323.47	355.22	405.89
l	57.15	66.68	76.20	101.6	127.00	152.40	180.00	205.00
L	78.0	108.0	118.5	143.0	194.0	235.5	226.0	258.5

牌 價 (單位 / 元)

品號	管帽								
	UPVC		CPVC		材質	UPVC		CPVC	
接口	S	T	S	T		接口	S	T	S
1/2"	83	103	141	184	4"	1490	1620	1536	1704
3/4"	87	116	200	261	5"	2470		4326	
1"	155	183	355	424	6"	3706		5090	
1-1/4"	187	222	388	469	8"	4800		15422	
1-1/2"	187	233	388	469	10"	9484		27133	
2"	370	417	409	490	12"	14232		37241	
2-1/2"	755	806	1378	1512	14"	30000			
3"	883	944	1511	1660	16"	35000			

*S為平口、T為牙口 | 大型尺寸可訂製

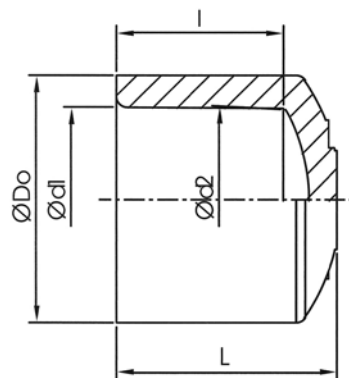

SCH 80 Y三通 / 異徑Y三通 Y-Tee / Reducer Y-Tee



Nom. SIZE	1/2"	3/4"	1"	1-1/4"	1-1/2"	2"	3"	4"	6"	8"
D0(mm)	30.5	36.0	44.0	61.0	61.0	76.5	106.0	132.0	191.0	246.0
d1	21.54	26.87	33.66	42.42	48.56	60.63	89.31	114.76	168.83	219.84
d2	21.23	26.57	33.27	42.04	48.11	60.17	88.70	114.07	168.00	218.69
l	25.22	28.50	31.58	34.75	37.93	41.50	49.00	59.00	79.00	104.6
d	19.0	24.5	31.0	40.0	46.0	58.5	74.0	100.0	150.0	200.0
L	90	105	117	150	150	181	222	277	393	570
H	34	40	42	52	52	60	68	83	114	177

牌 價 (單位 / 元)

Nom. SIZE	4"X4"X2"	8"X8"X4"	8"X8"X6"
D1	132	246	246
D2	76.5	132	191
d1	114.76	219.84	219.84
d2	114.1	218.69	218.69
l1	59	104.6	104.6
d3	60.63	114.76	168.83
d4	60.17	114.1	168
l2	41.5	59	79
L	267	491	570.5
H	70	129	177
d	100	200	200
do	54.5	100	150

品號	Y三通	
材質	UPVC	CPVC
接口	S	
1/2"	216	586
3/4"	242	890
1"	324	1500
1-1/2"	500	2442
2"	1429	5955
3"	4609	7951
4"	5710	8406
6"	7799	11505
8"	15191	23767
10"	37887	40811
12"	53511	56863

品號	異徑Y三通	
材質	UPVC	CPVC
接口	S	
4" X 4" X 2"	5710	
8" X 8" X 4"	12662	15826
8" X 8" X 6"	14935	21970

*S為平口、T為牙口 | 大型尺寸可訂製

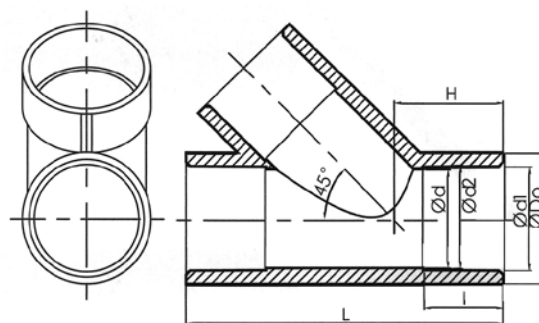
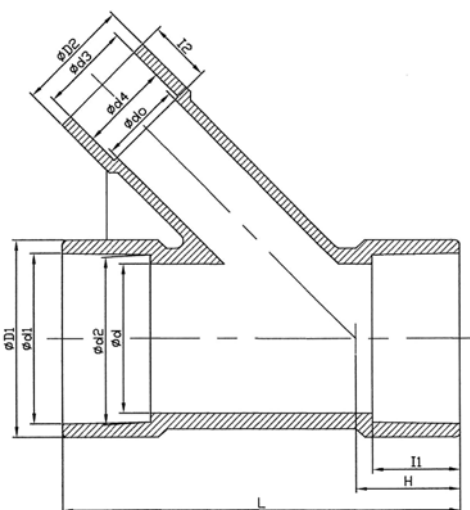

SCH 80 外牙接頭(閘接頭) Male Adapter



Slip x NPT

Nom. SIZE	1/2"	3/4"	1"	1-1/4"	1-1/2"	2"	2-1/2"	3"	4"
D0(mm)	30.5	35.0	44.0	54.0	60.0	73.0	88.0	105.0	132.0
d1	21.54	26.87	33.66	42.42	48.56	60.63	73.38	89.31	114.76
d2	21.23	26.57	33.27	42.04	48.11	60.17	72.85	88.70	114.07
l	22.22	25.40	28.58	31.75	34.93	38.10	44.45	47.63	57.15
d	13	17	23	29	37	48	57	72	96
S	9	9	9	9	9	10	11.5	14	14
L	50	50	59	61	72	77	97	103	116
L1	19	15	21	19	27	27	40	42	45
B	36	41	50	60	65	80	95	115	145
D1	38	43	53	63	68	83	100	122	154
NPT	14.0	14.0	11.5	11.5	11.5	11.5	8.0	8.0	8.0

Slip x BSPT

Nom. SIZE	1/2"	3/4"	1"	1-1/4"	1-1/2"	2"	2-1/2"	3"	4"
D0(mm)	30.5	35.0	44.0	54.0	60.0	73.0	88.0	105.0	132.0
d1	21.54	26.87	33.66	42.42	48.56	60.63	73.38	89.31	114.76
d2	21.23	26.57	33.27	42.04	48.11	60.17	72.85	88.70	114.07
l	22.22	25.40	28.58	31.75	34.93	38.10	44.45	47.63	57.15
d	13.0	17.0	23.0	29.5	37.0	48.0	57.0	72.0	96.0
S	9.0	9.0	9.0	9.0	9.0	10.0	11.5	14.0	14.0
L	50.0	50.0	55.0	61.0	64.0	70.5	90.0	94.5	109.5
L1	19.0	15.0	16.5	19.0	19.0	20.5	32.0	32.0	38.0
B	36	41	50	60	65	80	95	115	145
D1	38	43	53	63	68	83	100	122	154
BSPT	14	14	11	11	11	11	11	11	11

Slip x NPT

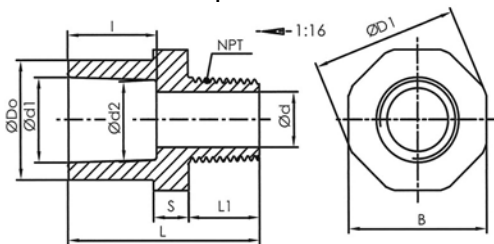

Slip x BSPT

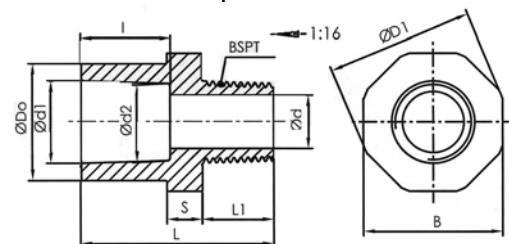

牌價 (單位 / 元)

品號	外牙接頭					
	材質	UPVC	CPVC	材質	UPVC	CPVC
接口	S X T		接口		S X T	
1/2"	99	105	2"	459	648	
3/4"	109	143	2-1/2"	522	1768	
1"	189	240	3"	580	2376	
1-1/4"	221	354	4"	1030	4016	
1-1/2"	318	478				

*S為平口、T為牙口 | 大型尺寸可訂製

SCH 80 異徑直接頭(大小頭) Reducer Coupling



SIZE	Nom.	D1(mm)	D2	d1	d2	l1	d3	d4	l2	d	L	L1
3/4" × 1/2"		37.0	30.5	26.87	26.57	25.40	21.54	21.23	22.22	16.5	57.5	30.0
1" × 1/2"		47.0	30.5	33.66	33.27	28.58	21.54	21.23	22.22	16.5	58.0	36.0
1" × 3/4"		47.0	35.0	33.66	33.27	28.58	26.87	26.57	25.40	21.0	61.0	36.0
1-1/4" × 1/2"		55.5	30.5	42.42	42.04	31.75	21.54	21.23	22.22	16.5	62.5	42.0
1-1/4" × 3/4"		55.5	35.0	42.42	42.04	31.75	26.87	26.57	25.40	21.0	65.0	42.0
1-1/4" × 1"		55.5	44.0	42.42	42.04	31.75	33.66	33.27	28.58	28.0	68.5	42.0
1-1/2" × 1/2"		63.0	30.5	48.56	48.11	34.93	21.54	21.23	22.22	16.5	65.0	44.0
1-1/2" × 3/4"		63.0	35.0	48.56	48.11	34.93	26.87	26.57	25.40	21.0	68.0	44.0
1-1/2" × 1"		63.0	44.0	48.56	48.11	34.93	33.66	33.27	28.58	28.0	71.0	44.0
1-1/2" × 1-1/4"		63.0	54.0	48.56	48.11	34.93	42.42	42.04	31.75	35.0	75.0	44.0
2" × 1/2"		75.0	30.5	60.63	60.17	38.10	21.54	21.23	22.22	16.5	68.0	49.5
2" × 3/4"		75.0	35.0	60.63	60.17	38.10	26.87	26.57	25.40	21.0	71.0	49.5
2" × 1"		75.0	44.0	60.63	60.17	38.10	33.66	33.27	28.58	28.0	74.5	49.5
2" × 1-1/4"		75.0	54.0	60.63	60.17	38.10	42.42	42.04	31.75	35.0	78.5	49.5
2" × 1-1/2"		75.0	60.0	60.63	60.17	38.10	48.56	48.11	34.93	42.5	82.5	49.5

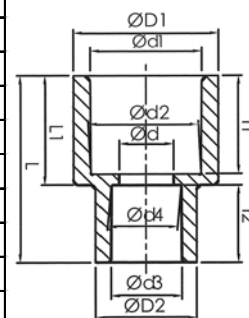

SIZE	Nom.	D1(mm)	D2	d1	d2	l1	d3	d4	l2	d	d0	L
2-1/2" × 1"		89.0	44.0	73.38	72.85	44.45	33.65	33.27	28.58	65.0	27.5	117.5
2-1/2" × 1-1/2"		89.0	61.0	73.38	72.85	44.45	48.56	48.11	34.93	65.0	42.5	124.0
2-1/2" × 2"		89.0	73.0	73.38	72.85	44.45	60.63	60.17	38.10	65.0	54.5	127.0
3" × 1-1/2"		106.0	61.0	89.31	88.70	47.63	48.56	48.11	34.93	81.0	42.5	136.0
3" × 2"		106.0	73.0	89.31	88.70	47.63	60.63	60.17	38.10	81.0	54.5	140.0
3" × 2-1/2"		106.0	89.0	89.31	88.70	47.63	73.38	72.85	44.45	81.0	65.0	147.0
4" × 2"		133.5	73.0	114.76	114.10	57.15	60.63	60.17	38.10	-	54.5	158.5
4" × 2-1/2"		133.5	89.0	114.76	114.10	57.15	73.38	72.85	44.45	-	65.0	158.5
4" × 3"		133.5	106.0	114.76	114.10	57.15	89.31	88.70	47.63	-	81.0	158.5

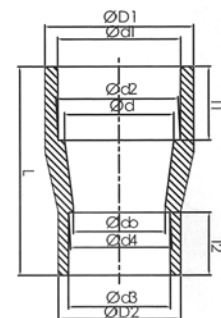

牌價 (單位 / 元)

品號	異徑直接頭											
	材質	UPVC	CPVC	材質	UPVC	CPVC	材質	UPVC	CPVC	材質	UPVC	CPVC
3/4" × 1/2"	103	236		1-1/2" × 1"	321	766		2-1/2" × 2"	439	1559		
1" × 3/8"	145			1-1/2" × 1-1/4"	362	766		3" × 1-1/2"	856	2785		
1" × 1/2"	145	337		2" × 1/2"	362	1013		3" × 2"	856	2785		
1" × 3/4"	151	337		2" × 3/4"	362	1013		3" × 2-1/2"	856	2785		
1-1/4" × 1/2"	307	772		2" × 1"	362	1013		4" × 2"	1067	3496		
1-1/4" × 3/4"	307	772		2" × 1-1/4"	362	1013		4" × 2-1/2"	1067	3496		
1-1/4" × 1"	307	772		2" × 1-1/2"	362	1013		4" × 3"	1067	3496		
1-1/2" × 1/2"	321	766		2-1/2" × 1"	439	1013		6" × 3"	4246	7515		
1-1/2" × 3/4"	321	766		2-1/2" × 1-1/2"	439	1559		8" × 3"	10360	11460		

*S為平口、T為牙口 | 大型尺寸可訂製

SCH 80 異徑三通 Reducer Tee



SIZE	Nom.	D1 (mm)	D2	d1	d2	l1	d3	d4	l2	L	H	d	d0
3/4" x 3/4" x 1/2"		37.0	32.0	26.87	26.57	25.40	21.54	21.23	22.22	88.0	38.5	22	16.5
1" x 1" x 1/2"		44.0	30.0	33.65	33.27	28.58	21.54	21.23	22.22	97.0	41.0	28	16.5
1" x 1" x 3/4"		44.0	37.0	33.65	33.27	28.58	26.87	26.57	25.40	97.0	44.0	28	22.0
1" x 1" x 2"		44.0	73.0	33.65	33.27	28.58	60.63	60.17	38.10	97.0	65.0	28	28.0
1-1/4" x 1-1/4" x 1/2"		54.0	30.0	42.42	42.04	31.75	21.54	21.23	22.20	116.0	44.5	35	16.5
1-1/4" x 1-1/4" x 3/4"		54.0	35.0	42.42	42.04	31.75	26.87	26.57	25.40	116.0	48.0	35	22.0
1-1/4" x 1-1/4" x 1"		54.0	44.0	42.42	42.04	31.75	33.65	33.27	28.58	116.0	52.0	35	28.0
1-1/2" x 1-1/2" x 1/2"		62.0	30.0	48.56	48.11	34.93	21.54	21.23	22.22	128.5	48.5	43	16.5
1-1/2" x 1-1/2" x 3/4"		62.0	35.0	48.56	48.11	34.93	26.87	26.57	25.40	128.5	52.0	43	22.0
1-1/2" x 1-1/2" x 1"		62.0	45.5	48.56	48.11	34.93	33.65	33.27	28.58	128.5	55.5	43	28.0
1-1/2" x 1-1/2" x 1-1/4"		62.0	54.0	48.56	48.11	34.93	42.42	42.04	31.75	128.5	60.0	43	35.0
2" x 2" x 1/2"		73.0	30.5	60.63	60.17	38.10	21.54	21.23	22.22	146.0	54.0	54	16.5
2" x 2" x 3/4"		73.0	35.0	60.63	60.17	38.10	26.87	26.57	25.40	146.0	57.5	54	22.0
2" x 2" x 1"		73.0	44.0	60.63	60.17	38.10	33.65	33.27	28.58	146.0	60.5	54	28.0
2" x 2" x 1-1/4"		73.0	54.0	60.63	60.17	38.10	42.42	42.04	31.75	146.0	65.0	54	35.0
2" x 2" x 1-1/2"		73.0	60.0	60.63	60.17	38.10	48.56	48.11	34.93	146.0	69.0	54	43.0
2-1/2" x 2-1/2" x 1"		89.0	44.0	73.38	72.85	44.45	33.65	33.27	28.58	171.0	67.5	65	28.0
2-1/2" x 2-1/2" x 1-1/4"		89.0	54.0	73.38	72.85	44.45	42.42	42.04	31.75	171.0	72.0	65	38.0
2-1/2" x 2-1/2" x 1-1/2"		89.0	60.0	73.38	72.85	44.45	48.56	48.11	34.93	171.0	75.5	65	43.0
2-1/2" x 2-1/2" x 2"		89.0	73.0	73.38	72.85	44.45	60.63	60.17	38.10	171.0	79.0	65	54.0
3" x 3" x 1"		105.0	44.0	89.31	88.70	47.63	33.65	33.27	28.58	196.0	77.5	80	28.0
3" x 3" x 1-1/4"		105.0	54.0	89.31	88.70	47.63	42.42	42.04	31.75	196.0	77.5	80	35.0
3" x 3" x 1-1/2"		105.0	60.0	89.31	88.70	47.63	48.56	48.11	34.93	196.0	82.0	80	43.0
3" x 3" x 2"		105.0	73.0	89.31	88.70	47.63	60.63	60.17	38.10	196.0	86.5	80	54.0
3" x 3" x 2-1/2"		105.0	89.0	89.31	88.70	47.63	73.38	72.85	44.45	196.0	95.0	80	65.0
4" x 4" x 1"		132.5	44.0	114.76	114.10	57.15	33.65	33.27	28.58	237.5	89.5	100	28.0
4" x 4" x 1-1/4"		132.5	54.0	114.76	114.10	57.15	42.42	42.04	31.75	237.5	90.5	100	38.0
4" x 4" x 1-1/2"		132.5	61.0	114.76	114.10	57.15	48.56	48.11	34.93	237.5	97.0	100	43.0
4" x 4" x 2"		132.5	73.0	114.76	114.10	57.15	60.63	60.17	38.10	237.5	96.0	100	54.0
4" x 4" x 2-1/2"		132.5	89.0	114.76	114.10	57.15	73.38	72.85	44.45	237.5	104.0	100	65.0
4" x 4" x 3"		132.5	105.0	114.76	114.10	57.15	89.31	88.70	47.63	237.5	110.0	100	80.0
5" x 5" x 2"		163.0	75.0	141.81	141.00	66.68	60.63	60.17	38.10	298.0	114.5	132	54.0
6" x 6" x 1"		191.0	45.0	168.83	168.00	76.20	33.65	33.27	28.58	336.5	115.0	150	29.0
6" x 6" x 1-1/4"		191.0	54.0	168.83	168.00	76.20	42.42	42.04	31.75	336.5	120.0	150	38.0
6" x 6" x 1-1/2"		191.0	60.5	168.83	168.00	76.20	48.56	48.11	34.93	336.5	123.0	150	44.0
6" x 6" x 2"		191.0	73.0	168.83	168.00	76.20	60.63	60.17	38.10	336.5	125.0	150	54.0
6" x 6" x 2-1/2"		191.0	89.0	168.83	168.00	76.20	73.88	72.85	44.45	336.5	130.0	150	65.0
6" x 6" x 3"		191.0	105.0	168.83	168.00	76.20	89.31	88.70	47.63	336.5	135.0	150	80.0
6" x 6" x 4"		191.0	132.0	168.83	168.00	76.20	114.76	114.10	57.15	336.5	145.0	150	100.0
8" x 8" x 2"		246.0	75.0	219.84	218.69	101.60	60.63	60.17	38.10	439.0	151.0	200	54.0
8" x 8" x 2-1/2"		246.0	89.0	219.84	218.69	101.60	73.38	72.85	44.45	439.0	157.25	200	65.0
8" x 8" x 3"		246.0	105.0	219.84	218.69	101.60	89.31	88.70	47.63	439.0	160.0	200	80.0
8" x 8" x 4"		246.0	132.0	219.84	218.69	101.60	114.76	114.10	57.15	439.0	170.0	200	100.0
8" x 8" x 6"		246.0	191.0	219.84	218.69	101.60	168.83	168.00	76.20	439.0	194.0	200	150.0
10" x 10" x 2"		307.0	74.0	273.81	272.67	127.00	60.63	60.17	38.10	560.0	185.0	265	54.0
10" x 10" x 3"		307.0	107.0	273.81	272.67	127.00	89.31	88.70	47.63	560.0	194.0	265	80.0
10" x 10" x 4"		307.0	134.0	273.81	272.67	127.00	114.76	114.10	57.15	560.0	205.0	265	100.0
10" x 10" x 6"		307.0	193.0	273.81	272.67	127.00	168.83	168.00	76.20	560.0	225.0	265	160.0
10" x 10" x 8"		307.0	248.0	273.81	272.67	127.00	219.84	218.69	101.60	560.0	250.0	265	210.0
12" x 12" x 2"		364.0	74.0	324.61	323.47	152.40	60.63	60.17	38.10	660.0	215.0	315	54.0
12" x 12" x 3"		364.0	108.0	324.61	323.47	152.40	89.31	88.70	47.63	660.0	225.0	315	80.0
12" x 12" x 4"		364.0	136.0	324.61	323.47	152.40	114.76	114.10	57.15	660.0	235.0	315	100.0
12" x 12" x 6"		364.0	195.0	324.61	323.47	152.40	168.83	168.00	76.20	660.0	255.0	315	160.0
12" x 12" x 8"		364.0	248.0	324.61	323.47	152.40	219.84	218.69	101.60	660.0	280.0	315	210.0
12" x 12" x 10"		364.0	308.0	324.61	323.47	152.40	273.81	272.67	127.00	660.0	298.0	315	265.0
14" x 14" x 4"		396.5	133.0	356.49	355.22	205.00	114.76	114.07	57.15	856.5	290.0	346	100.0
14" x 14" x 6"		396.5	192.0	356.49	355.22	*205.00	168.83	168.00	76.20	856.5	310.0	346	144.0
14" x 14" x 8"		396.5	246.0	356.49	355.22	*205.00	219.84	218.69	101.60	856.5	339.0	346	200.0
14" x 14" x 10"		396.5	307.0	356.49	355.22	*205.00	273.81	272.67	127.00	856.5	365.0	346	259.0
14" x 14" x 12"		396.5	364.0	356.49	355.22	*205.00	324.61	323.47	152.40	856.5	390.0	346	308.0

*該項未參照ASTM標準

牌 價 (單位 / 元)

品號	異徑三通		材質	UPVC	CPVC
	材質	UPVC			
接口	S×S×S		接口	S×S×S	
3/4" × 1/2"	101	448	4" × 2-1/2"	1191	3239
1" × 1/2"	146	516	4" × 3"	1191	3239
1" × 3/4"	146	516	5" × 2"	4577	7176
1" × 2"	390	1230	5" × 4"	4577	7176
1-1/4" × 1/2"	241	1009	6" × 1"	3196	9145
1-1/4" × 3/4"	241	1009	6" × 1-1/4"	3196	9145
1-1/4" × 1"	241	1009	6" × 1-1/2"	3196	9145
1-1/2" × 1/2"	317	1054	6" × 2"	3196	9145
1-1/2" × 3/4"	317	1054	6" × 2-1/2"	3196	9145
1-1/2" × 1"	317	1054	6" × 3"	3196	9145
1-1/2" × 1-1/4"	317	1054	6" × 4"	3196	9145
2" × 1/2"	402	1256	8" × 2"	11565	30757
2" × 3/4"	402	1256	8" × 2-1/2"	11803	35088
2" × 1"	402	1256	8" × 3"	11803	35088
2" × 1-1/4"	402	1256	8" × 4"	12412	35088
2" × 1-1/2"	402	1256	8" × 6"	7412	16788
2-1/2" × 1"	600	1712	10" × 2"	17700	56756
2-1/2" × 1-1/4"	600	1712	10" × 3"	18633	59744
2-1/2" × 1-1/2"	600	1712	10" × 4"	19303	63175
2-1/2" × 2"	600	1712	10" × 6"	21830	71036
3" × 1"	737	2562	10" × 8"	24490	81072
3" × 1-1/4"	737	2562	12" × 2"	23170	83008
3" × 1-1/2"	737	2562	12" × 3"	24388	87378
3" × 2"	737	2562	12" × 4"	25671	91977
3" × 2-1/2"	737	2562	12" × 6"	27305	101335
4" × 1"	1191	3239	12" × 8"	30412	105356
4" × 1-1/4"	1191	3239	12" × 10"	33794	129731
4" × 1-1/2"	1191	3239	14" × 4"	78500	150000
4" × 2"	1191	3239	14" × 6"	80000	155000

*S為平口、T為牙口 | 大型尺寸可訂製

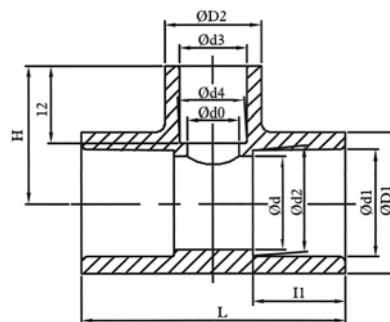

SCH 80 異徑接頭(卜申) Reducer Bushing

Slip x Slip



SIZE	Nom.	D0(mm)	d1	d2	l	d	L	L1	D1	B
1/2" x 1/4"		21.34	14.02	13.61	19.0	10.0	29	23.0	31.0	30
1/2" x 3/8"		21.34	17.45	17.04	22.0	12.0	29	23.0	31.0	30
3/4" x 1/2"		26.67	21.54	21.23	24.0	13.0	33	27.0	31.0	30
1" x 3/8"		33.40	17.45	17.04	24.0	12.0	38	30.0	39.4	38
1" x 1/2"		33.40	21.54	21.23	24.0	12.0	38	30.0	39.4	38
1" x 3/4"		33.40	26.87	26.57	28.0	18.0	38	30.0	39.4	38
1-1/4" x 1/2"		42.16	21.54	21.23	24.22	16.5	44	35.0	52.0	50
1-1/4" x 3/4"		42.16	26.87	26.57	27.4	21.0	44	35.0	52.0	50
1-1/4" x 1"		42.16	33.66	33.27	30.58	28.0	44	35.0	52.0	50
1-1/2" x 1/2"		48.26	21.54	21.23	24.22	16.5	47	38.0	58.0	55
1-1/2" x 3/4"		48.26	26.87	26.57	27.4	21.0	47	38.0	58.0	55
1-1/2" x 1"		48.26	33.66	33.27	30.58	28.0	47	38.0	58.0	55
1-1/2" x 1-1/4"		48.26	42.42	42.04	34.75	35.0	47	38.0	58.0	55
2" x 1/2"		60.33	21.54	21.23	24.22	12.0	52	42.0	68.0	65
2" x 3/4"		60.33	26.87	26.57	27.4	21.0	52	42.0	68.0	65
2" x 1"		60.33	33.66	33.27	30.58	28.0	52	42.0	68.0	65
2" x 1-1/4"		60.33	42.42	42.04	34.75	35.0	52	42.0	68.0	65
2" x 1-1/2"		60.33	48.56	48.11	37.93	43.0	52	42.0	68.0	65
2-1/2" x 1"		73.03	33.66	33.27	30.6	28.0	60	48.5	85.0	80
2-1/2" x 1-1/4"		73.03	42.42	42.04	34.8	36.0	60	48.5	85.0	80
2-1/2" x 1-1/2"		73.03	48.56	48.11	37.93	43.0	60	48.5	85.0	80
2-1/2" x 2"		73.03	60.63	60.17	41.1	52.0	60	48.5	85.0	80
3" x 1"		88.90	33.65	33.27	30.5	28.0	65	51.0	105.0	99
3" x 1-1/2"		88.90	48.56	48.11	37.93	43.0	65	51.0	105.0	99
3" x 2"		88.90	60.63	60.17	41.1	54.0	65	51.0	105.0	99
3" x 2-1/2"		88.90	73.38	72.85	47.45	65.0	65	51.0	105.0	99
4" x 1"		114.30	33.65	33.27	30.5	28.0	75	60.5	132.0	125
4" x 2"		114.30	60.63	60.17	41.1	54.0	75	60.5	132.0	125
4" x 2-1/2"		114.30	73.38	72.85	47.45	65.0	75	60.5	132.0	125
4" x 3"		114.30	89.31	88.70	50.63	80.0	75	60.5	132.0	125
5" x 4"		114.30	114.76	114.10	60.2	100.0	84	69.6	150.0	145
6" x 2"		168.28	60.63	60.17	41.1	51.0	90	76.5	191.0	180
6" x 3"		168.28	89.31	88.70	50.6	80.0	90	76.5	191.0	180
6" x 4"		168.28	114.76	114.10	60.2	105.0	90	76.5	191.0	180
6" x 5"		168.28	141.81	141.00	69.6	125.0	90	76.5	191.0	180
8" x 4"		219.10	114.76	114.10	60.5	105.0	120	104.6	246.0	235
8" x 6"		219.10	168.83	168.00	79.0	150.0	120	104.6	246.0	235
10" x 3"		273.05	89.31	88.70	50.6	80.0	148	130.0	290.0	280
10" x 4"		273.05	114.76	114.10	60.2	105.0	148	130.0	290.0	280
10" x 6"		273.05	168.83	168.00	79.2	150.0	148	130.0	290.0	280
10" x 8"		273.05	219.84	218.69	105.0	200.0	148	130.0	290.0	280
12" x 4"		323.85	114.76	114.10	60.2	100.0	175	155.0	345.0	330
12" x 6"		323.85	168.83	168.00	79.2	150.0	175	155.0	345.0	330
12" x 8"		323.85	219.84	218.69	105.0	200.0	175	155.0	345.0	330
12" x 10"		323.85	273.81	272.67	130.0	245.0	175	155.0	345.0	330
14" x 10"		355.60	324.61	323.47	130.0	245.0	200	180.0	380.0	360
14" x 12"		355.60	324.61	323.47	135.0	300.0	200	180.0	380.0	360

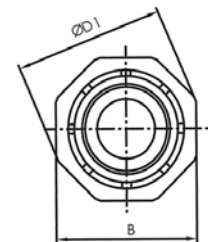
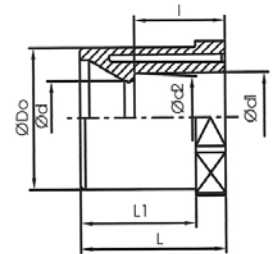

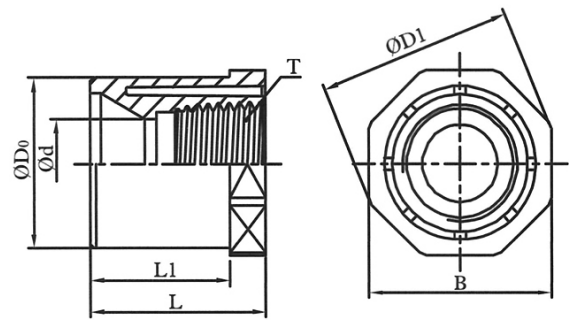

Slip x NPT

SIZE	Nom.	D0 (mm)	d	L	L1	B	D1	NPT (thd./in)
1/2" x 1/4"		21.34	11.0	29	23	30	31.0	18
1/2" x 3/8"		21.34	12.0	29	23	30	31.0	18
3/4" x 1/2"		26.67	13.0	33	27	30	31.0	14
1" x 3/8"		33.40	12.0	38	30	38	39.5	18
1" x 1/2"		33.40	12.0	38	30	38	39.5	14
1" x 3/4"		33.40	18.0	38	30	38	39.5	14
1-1/4" x 1/2"		42.16	16.5	44				
1-1/4" x 3/4"		42.16	21.0	44				
1-1/4" x 1"		42.16	28.0	44				

SIZE	Nom.	D0 (mm)	d	L
1-1/2" x 1/2"		48.26	16.5	47
1-1/2" x 3/4"		48.26	21.0	47
1-1/2" x 1"		48.26	28.0	47
1-1/2" x 1-1/4"		48.26	35.0	47
2" x 1/2"		60.33	12.0	52
2" x 3/4"		60.33	21.0	52
2" x 1"		60.33	28.0	52
2" x 1-1/4"		60.33	35.0	52
2" x 1-1/2"		60.33	43.0	52

牌價 (單位 / 元)

品號	異徑接頭			
	UPVC		CPVC	
材質				
接口	S×S	S×T	S×S	S×T
1/2" x 1/4"	75	100	187	204
1/2" x 3/8"	75	100	189	208
3/4" x 1/2"	27	50	97	105
1" x 3/8"	78	105	149	168
1" x 1/2"	78	105	149	168
1" x 3/4"	78	105	149	168
1-1/4" x 1/2"	123	160	398	426
1-1/4" x 3/4"	123	160	398	426
1-1/4" x 1"	123	160	398	426
1-1/2" x 1/2"	167	200	449	530
1-1/2" x 3/4"	167	200	449	530
1-1/2" x 1"	167	200	449	530
1-1/2" x 1-1/4"	167	200	449	
2" x 1/2"	238	305	580	741
2" x 3/4"	238	305	580	741
2" x 1"	238	305	580	741
2" x 1-1/4"	238	305	580	741
2" x 1-1/2"	238	305	580	741
2-1/2" x 1-1/4"	413		706	
2-1/2" x 1-1/2"	413		706	
2-1/2" x 2"	413		706	
3" x 1"	656		1076	
3" x 1-1/2"	656		1076	

*S為平口、T為牙口 | 大型尺寸可訂製

SCH 40 透明流體管

Clear PVC Pipe



Nom. \ SIZE	1/2"	3/4"	1"	1-1/4"	1-1/2"	2"	2-1/2"
D(mm)	21.34	26.67	33.40	42.16	48.26	60.33	73.03
Tolerance	±0.10	±0.10	±0.13	±0.13	±0.15	±0.15	±0.18
t(min)	2.77	2.87	3.38	3.56	3.68	3.91	5.16
Tolerance	+0.51	+0.51	+0.51	+0.51	+0.51	+0.51	+0.61

Nom. \ SIZE	3"	4"	*6"	*8"	*10"	*12"	
D(mm)	88.90	114.30	168.28	219.08	273.05	323.85	
Tolerance	±0.20	±0.23	±0.28	±0.38	±0.38	±0.38	
t(min)	5.49	6.02	7.11	8.18	9.27	10.31	
Tolerance	+0.66	+0.71	+0.86	+0.99	+1.12	+1.24	

*該項未參照ASTM標準

牌 價 (單位：米/元)

品號	透明流體管		
材質	PVC	材質	PVC
1/2"	248	2-1/2"	1720
3/4"	332	3"	2280
1"	500	4"	3210
1-1/4"	780	6"	4135
1-1/2"	800	8"	7230
2"	1100		

*大型尺寸可訂製

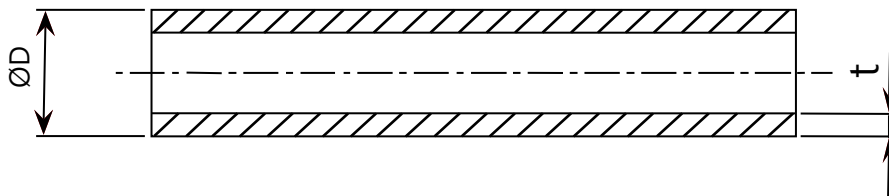

SCH 40 90° 透明彎頭

Clear 90° Elbow



SCH40

Nom. SIZE	1/2"	3/4"	1"	1-1/4"	1-1/2"	2"	2-1/2"	3"	4"
D0(mm)	27.50	33.60	41.70	50.50	56.80	69.00	84.20	100.8	127.3
d1	21.54	26.87	33.66	42.42	48.56	60.63	73.38	89.31	114.76
d2	21.23	26.57	33.27	42.04	48.11	60.17	72.85	88.70	114.07
l	17.80	18.70	22.70	24.30	28.30	29.90	45.00	48.10	51.30
d	18.00	22.50	29.00	38.00	43.50	55.00	67.50	83.50	108.5
G	12.70	14.80	18.30	22.70	25.70	32.00	39.00	46.50	59.70

牌 價 (單位 / 元)

品號	透明90°彎頭	
材質	PVC	材質 PVC
1/2"	216	2-1/2" 3182
3/4"	240	3" 4708
1"	432	4" 5722
1-1/4"	759	6" 11236
1-1/2"	810	8" 22257
2"	1276	

*大型尺寸可訂製

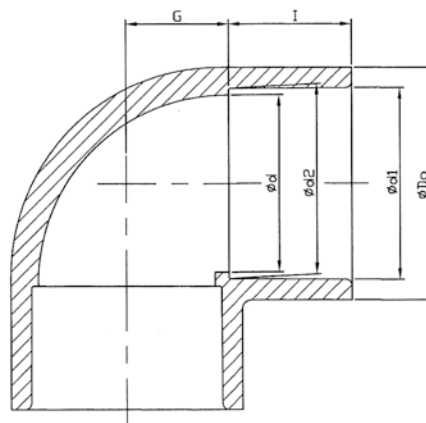

SCH 40 45° 透明彎頭

Clear 45° Elbow



SCH40

Nom. SIZE	1/2"	3/4"	1"	1-1/4"	1-1/2"	2"	2-1/2"	3"	4"
D0(mm)	27.50	33.10	40.90	50.10	56.50	69.00	84.20	100.8	127.3
d1	21.54	26.87	33.65	42.42	48.56	60.63	73.38	89.31	114.76
d2	21.23	26.57	33.27	42.04	48.11	60.17	72.85	88.70	114.07
l	17.80	18.70	22.70	24.30	28.30	29.90	45.00	48.10	51.30
d	18.00	22.50	29.00	38.00	43.50	55.00	67.50	83.50	108.50

牌 價 (單位 / 元)

品號	透明45°彎頭	
材質	PVC	材質 PVC
1/2"	353	2" 1518
3/4"	552	2-1/2" 3429
1"	661	3" 5650
1-1/4"	979	4" 6500
1-1/2"	1164	6" 13032

*大型尺寸可訂製

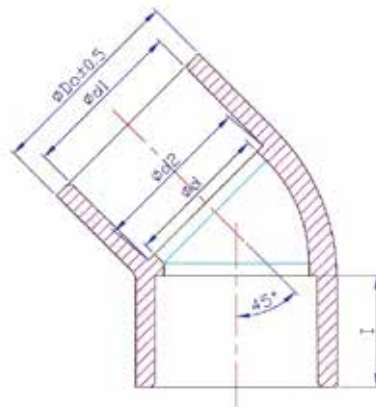

SCH 40 透明直接頭 Clear Coupling



SCH40

Nom. SIZE	1/2"	3/4"	1"	1-1/4"	1-1/2"	2"	2-1/2"	3"	4"
D0(mm)	27.5	33.5	41.7	50.2	56.8	69.0	84.2	100.8	127.3
d1	21.54	26.87	33.66	42.42	48.56	60.63	73.38	89.31	114.76
d2	21.23	26.57	33.27	42.04	48.11	60.17	72.85	88.70	114.07
l	17.80	18.70	22.70	24.30	28.30	29.90	45.00	48.10	51.30
d	18.00	22.50	29.00	38.00	43.50	55.50	67.50	83.50	108.50
L	38.60	40.50	48.50	57.50	60.00	63.50	95.00	101.20	107.60

牌 價 (單位 / 元)

品號	透明直接頭	
材質	PVC	材質 PVC
1/2"	146	2-1/2" 1800
3/4"	190	3" 2676
1"	332	4" 3448
1-1/4"	421	6" 6841
1-1/2"	492	8" 15114
2"	764	

* 大型尺寸可訂製

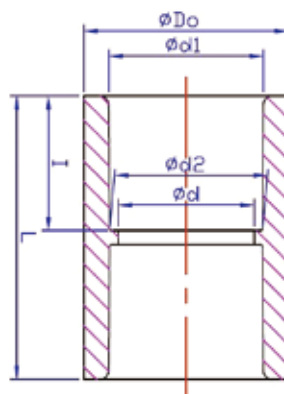

SCH 40 透明三通 Clear Tee



SCH40

Nom. SIZE	1/2"	3/4"	1"	1-1/4"	1-1/2"	2"	2-1/2"	3"	4"
D0(mm)	27.50	33.60	41.70	50.50	56.80	69.00	84.20	100.8	127.3
d1	21.54	26.87	33.66	42.42	48.56	60.63	73.38	89.31	114.76
d2	21.23	26.57	33.27	42.04	48.11	60.17	72.85	88.70	114.07
l	17.80	18.70	22.70	24.30	28.30	29.90	45.00	48.10	51.30
d	18.00	22.50	29.00	38.00	43.50	55.00	67.50	83.50	108.5
L	61.00	67.00	82.00	94.00	108.0	124.0	168.0	189.2	222.0
H	30.50	33.50	41.00	47.00	54.00	62.00	84.00	94.60	111.0

牌價 (單位 / 元)

品號	透明三通		
材質	PVC	材質	PVC
1/2"	308	2-1/2"	4474
3/4"	342	3"	6120
1"	616	4"	7000
1-1/4"	1004	6"	15495
1-1/2"	1154	8"	27159
2"	1814		

* 大型尺寸可訂製

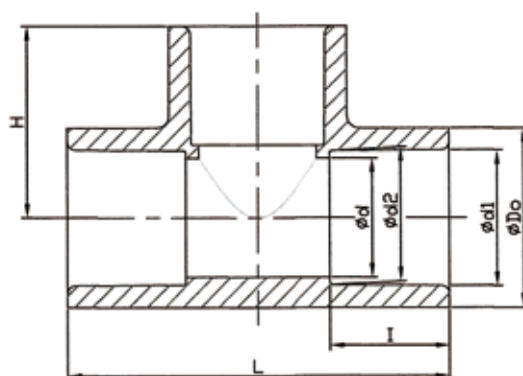

膠水、預黏膠、焊條 Glue、Wash Clean、Flux

牌 價 (單位 / 元)

品號	膠水				
型號	711	724	705	717	
材質	UPVC	CPVC	UPVC	UPVC	
顏色	灰	淺灰	透明	透明	
0.5 L	771	912	753		
1.0 L	1541	1824		1506	
品號	預黏膠		品號	焊條	
型號	P-68	P-70	型號	202	201
材質	UPVC/CPVC		材質	UPVC	CPVC
顏色	透明	透明	顏色	深灰	淺灰
0.5 L	660		1.0KG	1111	2041
1.0 L		1318			

膠水接口固化時間

相對溼度 60%或以下	1/2"~1-1/4"		1-1/2"~2"		2-1/2"~8"		10"~15"	15"~24"
在安裝和硬化時的周圍溫度	160psi或以下	160psi~370psi	160psi或以下	160psi~315psi	160psi或以下	160psi~315psi	100psi或以下	100psi或以下
15.5°C~37.8°C	15分鐘	6小時	30分鐘	12小時	1.5小時	24小時	48小時	72小時
4.4°C~15.5°C	20分鐘	12小時	45分鐘	24小時	4小時	48小時	96小時	6天
-17.7°C~4.4°C	30分鐘	48小時	1小時	96小時	72小時	8天	8天	14天

說明

- 1.如在相對溼度60%(含)以上之環境，建議最短等待時間延長1.5倍
- 2.在管路完整固化後，即可進行壓力測試，並將管路內注滿水，需將氣體完全排出
- 3.請勿使用空氣或壓縮氣體進行壓力測試，以免發生管路爆裂之風險
- 4.請按實務操作評估使用，本數據僅供參考



P.61

實績表

Performance table

項次	類別	工程名稱	用途	備註
1	半導體	日月光K4,16,21,22,24廠	化學、製程氣體、純水、廢水管路	
2	半導體	台積電2,4,5,6,7,8,10廠(上海)	純水、化學、廢水、雙套管路系統、真空	
3	半導體	台積電12P1-6,14A,14B廠	製程、給水、廢水、雙套管路系統	
4	半導體	台積電15P1-7,16(南京),18P1-6廠	高低真空、純水、廢水系統、雙套管路系統	
5	半導體	矽品精密(大豐、潭子)	製程、排酸暨雙套管路系統	
6	半導體	力晶科技P1,P2,P3	製程管路系統、CDA、雙套管路系統	
7	半導體	北京中芯	化學管路	
8	半導體	旺宏電子2,3,5廠	廢水、化學、排酸暨雙套管	
9	半導體	華亞科技	廢排水管路系統	
10	半導體	力成A3C3,P8(湖口、竹科)	真空、純水製程、二次配	
11	半導體	聯電8CDEF(竹科)	純水、製程、廢水、雙套管路系統	
12	半導體	集光A2(后里)	化學二次配	
13	電子業	康寧玻璃(中科、善化)	製程排水、水處理及廢水處理系統	
14	電子業	Google台灣資料中心(彰濱)	給水、冷卻管路系統	
15	電子業	可成科技股份有限公司	製程管路系統	
16	電子業	景碩科技(石碇、新豐)	給水、廢水處理系統、宿舍工程配管	
17	電子業	華邦電(中科)	製程、化學、廢排水管路	
18	電子業	華新科技A15廠	製程管路系統、廢排水	
19	電子業	大立光(台中)	製程、真空、排水管路	
20	電子業	達邁科技(鋼科)	廢水處理系統	
21	面板業	友達電L3,L8,L10,L11	製程、給水、廢水、雙套管路系統	
22	面板業	奇美電3,4,5,7,8(路科)廠	製程、廢水、高低真空、雙套管路系統	
23	傳產化工	力鵬紡織	純水、化學、雙套管路系統	
24	傳產化工	上海寶鋼鋼鐵廠	製程管路系統	
25	傳產化工	長春石化、李長榮、金居銅箔	銅箔製程管路系統	
26	傳產化工	燁隆、燁聯鋼鐵	酸洗暨化學管路系統	
27	傳產化工	三福化工(善化廠)	廢水管路系統	
28	傳產化工	台塑六輕	海水淡化、化學管路	
29	傳產化工	允強(雲林)	廢水處理系統	
30	傳產化工	康普科技(湖口)	製程管路系統	
31	公共民生	澎湖海洋生物研究中心	海水輸送、生物維生管路系統	
32	公共民生	日暉國際渡假村	給水、排水輸送管路	
33	公共民生	陽明山天籟溫泉	硫磺溫泉輸送管	
34	公共民生	核能二、三廠	海水電解、冷卻水管路系統	
35	汙水廠	中科、中洲、迪化污水處理廠	水處理及加藥系統管路	
36	海淡廠	馬祖南竿海淡廠(三期)	海水輸送系統	
37	海淡廠	澎佳嶼、澎湖馬公、各鹽井海淡廠	海水輸送系統	
38	焚化爐	仁武、永康、后里、溪洲焚化爐	水系統、加藥、冷卻水、廢水管路系統	
39	發電廠	林口、大潭、龍井發電廠	海水電解、輸送、加氯、廢水系統	
40	發電廠	通霄、澎湖、興達發電廠	空調冷卻水、輸送、廢水系統	
41	醫院	台新、光田、中國醫、亞東醫院	純水、洗腎水管路系統	
42	醫院	彰基、屏省、童綜合、關渡醫院	醫療用水、洗腎水管路系統	
以上僅為歷年來部分應用實績，請參考				

